



**ACCU-SCOPE®**

**MANUAL**

**EXC-350**  
**MICROSCOPE SERIES**



# CONTENTS

SAFETY NOTES .....	3
CARE AND MAINTENANCE .....	3
INTRODUCTION .....	4
UNPACKING AND COMPONENTS DIAGRAMS .....	4-6
ASSEMBLY DIAGRAM & PROCEDURE .....	7-10
<b>ADJUSTMENT &amp; OPERATION</b>	
ILLUMINATION .....	11
SPECIMEN SLIDE .....	11
FOCUSING .....	11-12
INTERPUPILLARY DISTANCE .....	12
CONDENSER .....	13
FIELD IRIS DIAPHRAGM .....	13
APERTURE DIAPHRAGM .....	13
OIL OBJECTIVE .....	14
FILTER .....	14
FUSE REPLACEMENT .....	15
CAMERA ADAPTER .....	15
SIMPLE POLARIZER .....	16
LED FLUORESCENCE .....	17-18
TURRET PHASE CONTRAST .....	19-22
TURRET PHASE CONTRAST & DARKFIELD .....	22
SLIDER PHASE CONTRAST .....	22-24
TROUBLESHOOTING .....	25-27
MAINTENANCE .....	28
SERVICE .....	28
WARRANTY .....	28

## **SAFETY NOTES**

1. Open the shipping carton carefully to prevent any accessory, i.e. objectives or eyepieces, from dropping and being damaged.
2. Do not discard the molded foam container; the container should be retained should the microscope ever require reshipment.
3. Keep the instrument out of direct sunlight, high temperature or humidity, and dusty environments. Ensure the microscope is located on a smooth, level and firm surface.
4. If any specimen solutions or other liquids splash onto the stage, objective or any other component, disconnect the power cord immediately and wipe up the spillage. Otherwise, the instrument may be damaged.
5. All electrical connectors (power cord) should be inserted into an electrical surge suppressor to prevent damage due to voltage fluctuations.
6. For safety when replacing the LED bulb or fuse, be sure the main switch is off ("O"), remove the power cord, and replace the LED bulb after the bulb and the lamp house has completely cooled.
7. Confirm that the input voltage indicated on your microscope corresponds to your line voltage. The use of a different input voltage other than indicated will cause severe damage to the microscope.

## **CARE AND MAINTENANCE**

1. Do not attempt to disassemble any component including eyepieces, objectives or focusing assembly.
2. Keep the instrument clean; remove dirt and debris regularly. Accumulated dirt on metal surfaces should be cleaned with a damp cloth. More persistent dirt should be removed using a mild soap solution. Do not use organic solvents for cleansing.
3. The outer surface of the optics should be inspected and cleaned periodically using an air stream from an air bulb. If dirt remains on the optical surface, use a soft cloth or cotton swab dampened with a lens cleaning solution (available at camera stores). All optical lenses should be swabbed using a circular motion. A small amount of absorbent cotton wound on the end of a tapered stick such as cotton swabs or Q-tips, makes a useful tool for cleaning recessed optical surfaces. Avoid using an excessive amount of solvents as this may cause problems with optical coatings or cemented optics or the flowing solvent may pick up grease making cleaning more difficult. Oil immersion objectives should be cleaned immediately after use by removing the oil with lens tissue or a clean, soft cloth.
4. Store the instrument in a cool, dry environment. Cover the microscope with the dust cover when not in use.
5. ACCU-SCOPE® microscopes are precision instruments which require periodic preventative maintenance to maintain proper performance and to compensate for normal wear. An annual schedule of preventative maintenance by qualified personnel is highly recommended. Your authorized ACCU-SCOPE® distributor can arrange for this service.

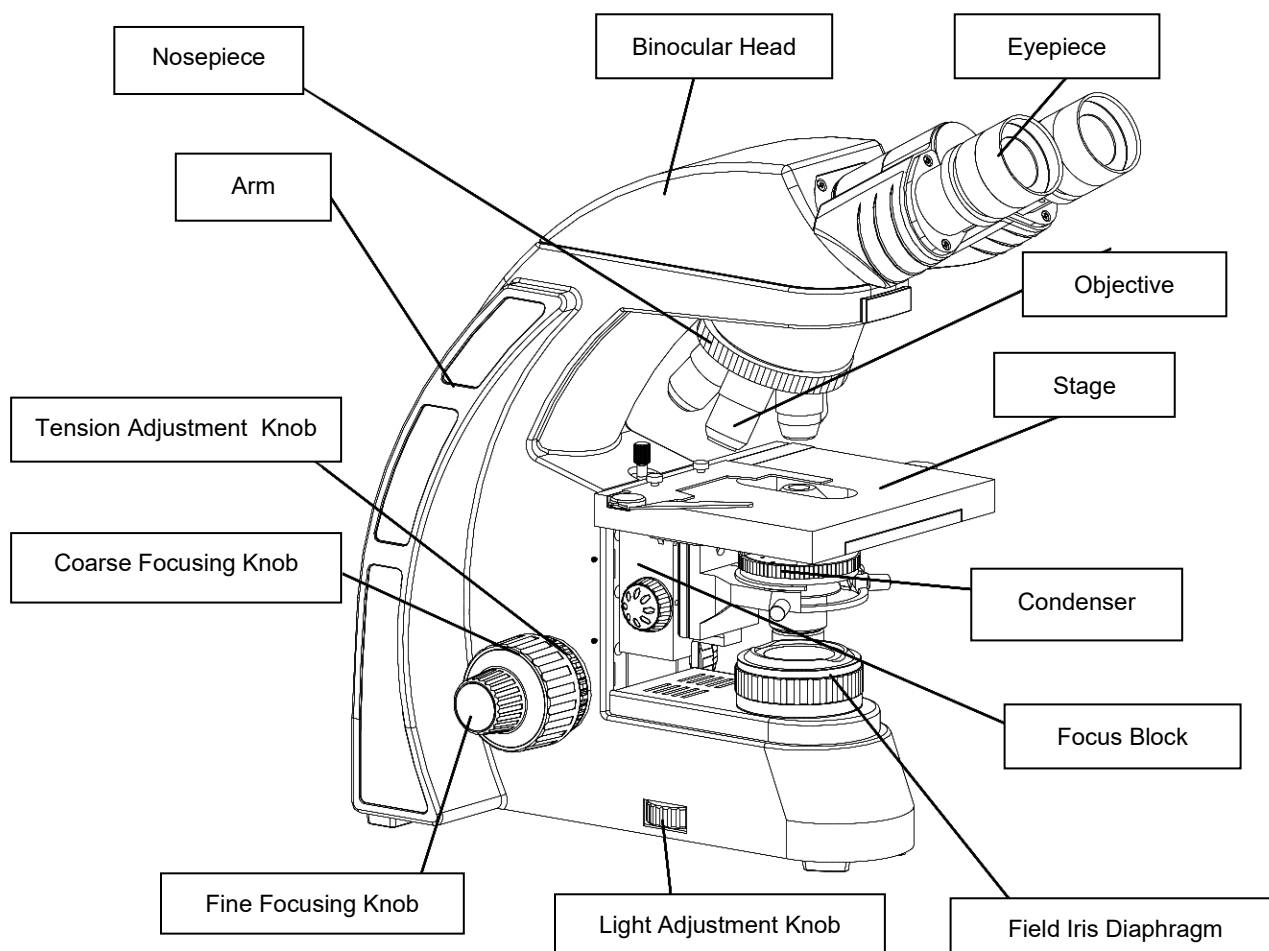
## INTRODUCTION

Congratulations on the purchase of your new ACCU-SCOPE<sup>®</sup> microscope. ACCU-SCOPE<sup>®</sup> microscopes are engineered and manufactured to the highest quality standards. Your microscope will last a lifetime if used and maintained properly. ACCU-SCOPE<sup>®</sup> microscopes are carefully assembled, inspected and tested by our staff of trained technicians in our New York facility. Careful quality control procedures ensure each microscope is of the highest quality prior to shipment.

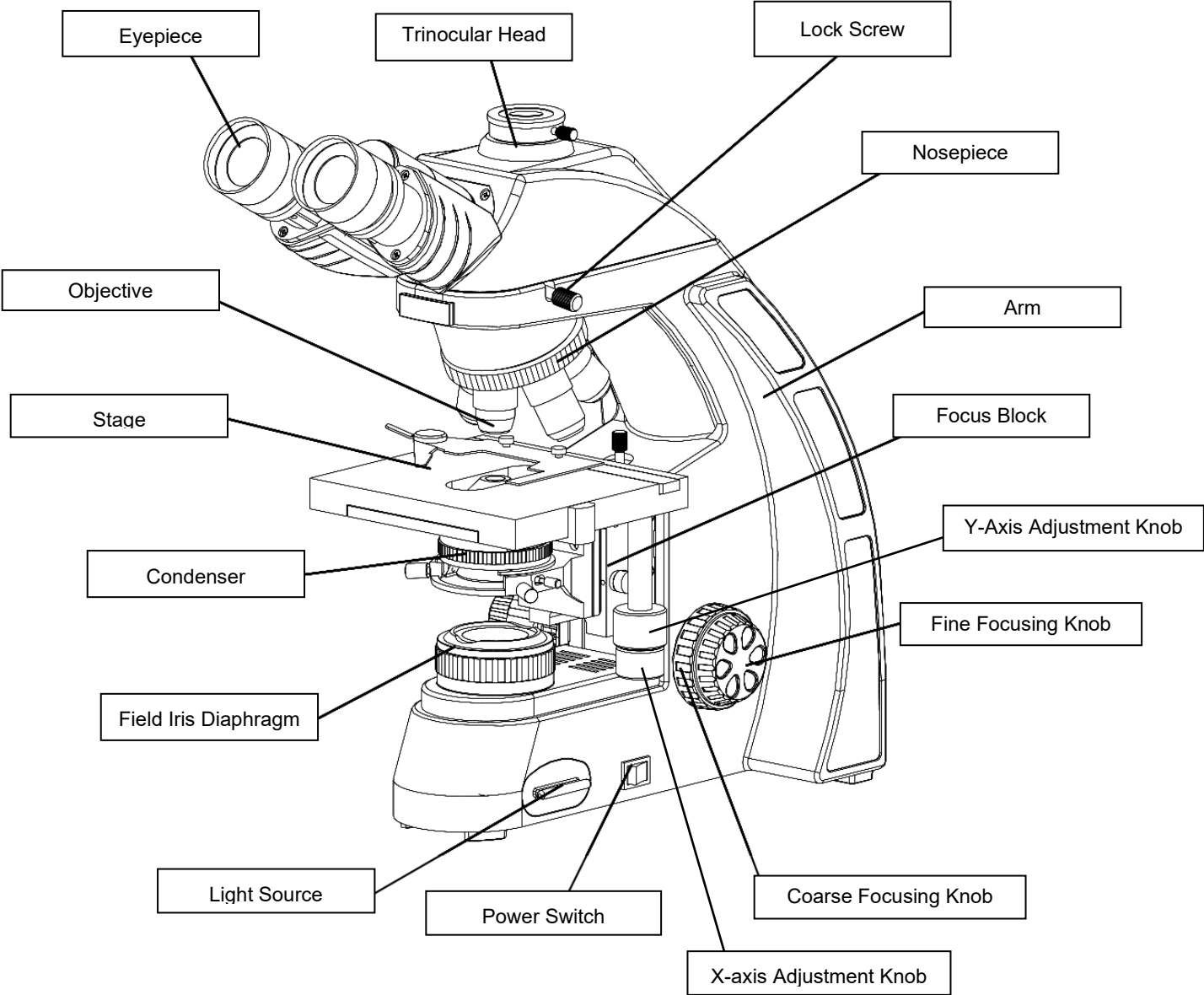
## UNPACKING AND COMPONENTS

Your microscope arrived packed in a molded Styrofoam container. ***Do not discard the container:*** the Styrofoam container should be retained for reshipment of your microscope if needed. Avoid placing the microscope in dusty surroundings or in high temperature or humid areas as mold and mildew will form. Carefully remove the microscope from the Styrofoam container by its arm and base and place the microscope on a flat, vibration-free surface.

## COMPONENTS DIAGRAM

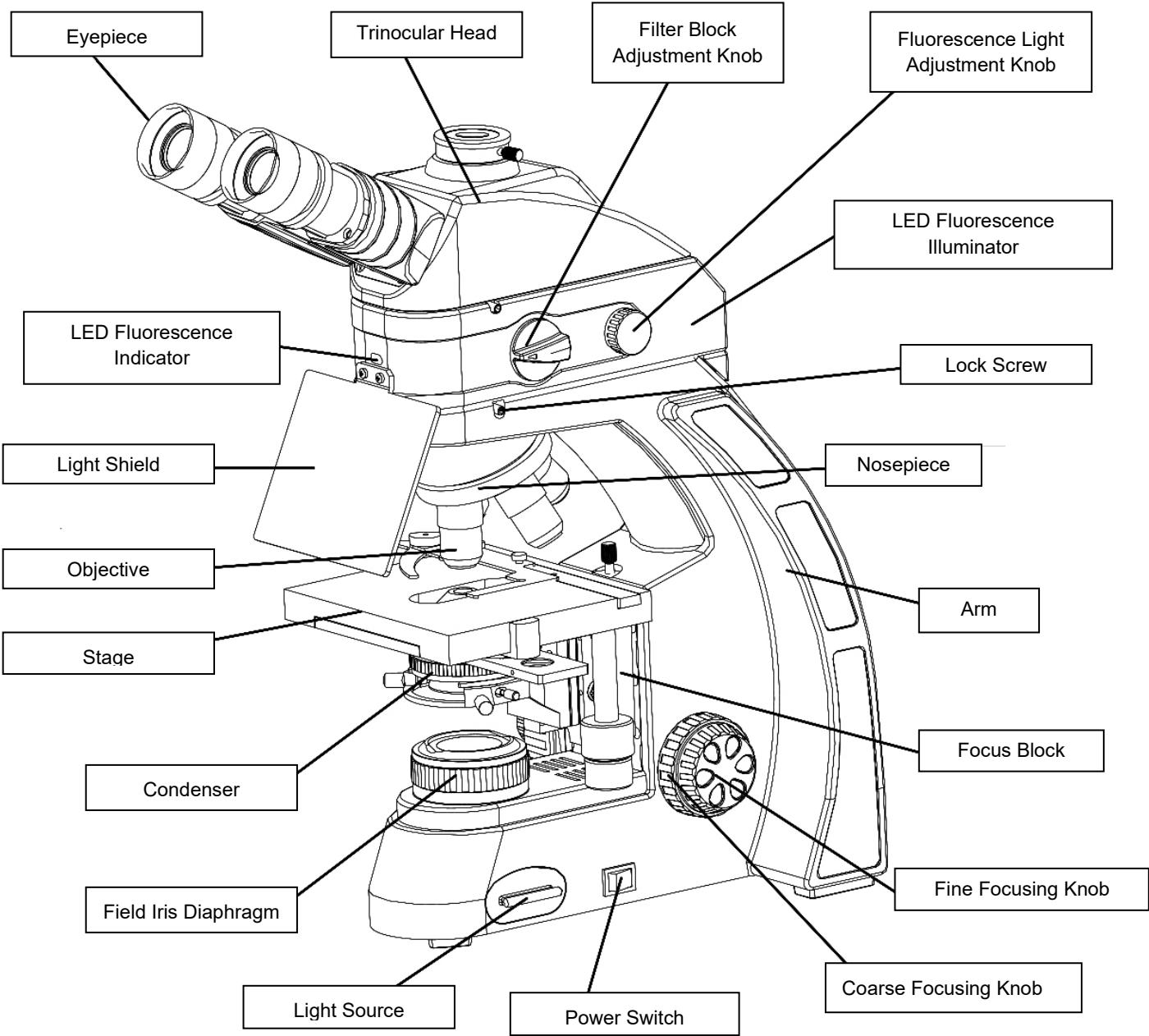


COMPONENTS DIAGRAM



COMPONENTS DIAGRAM

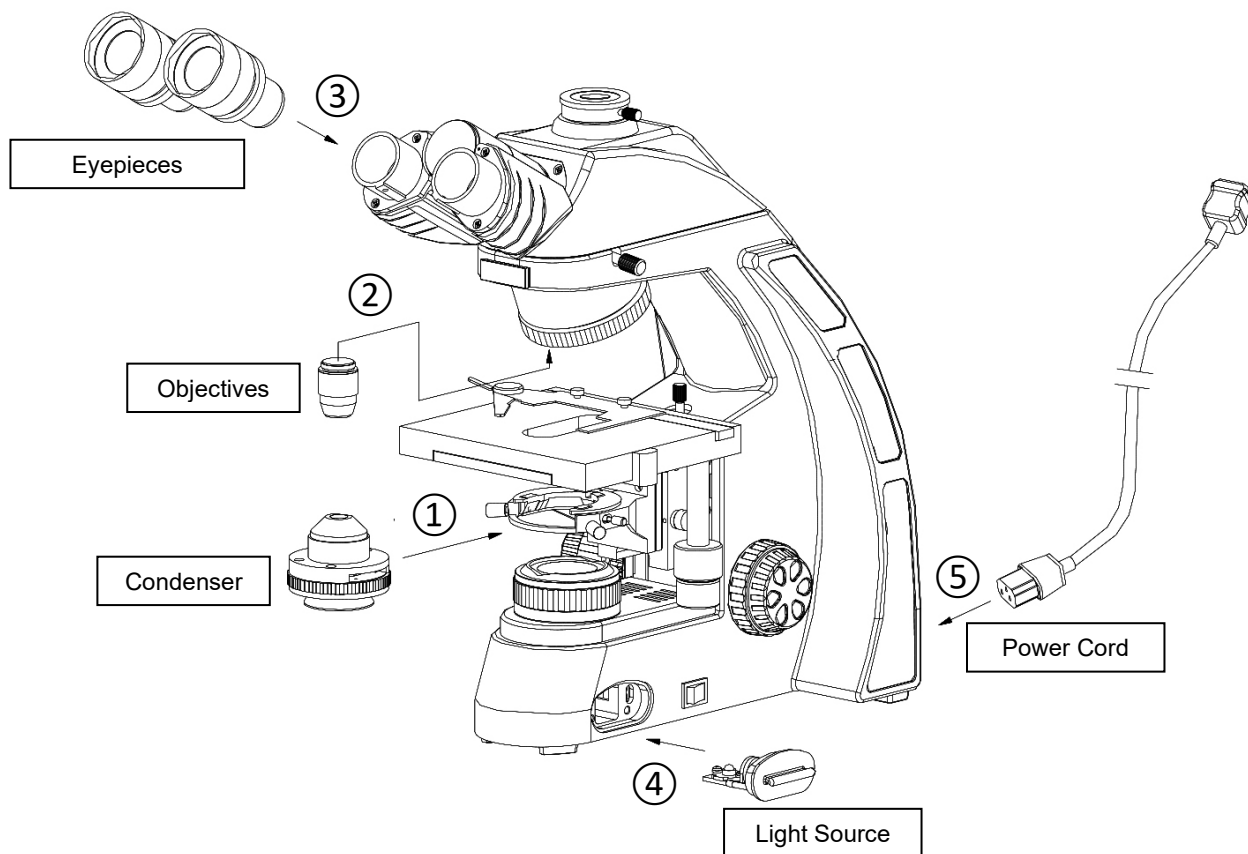
EXC-350-470 Fluorescence Microscope



## ASSEMBLY DIAGRAM

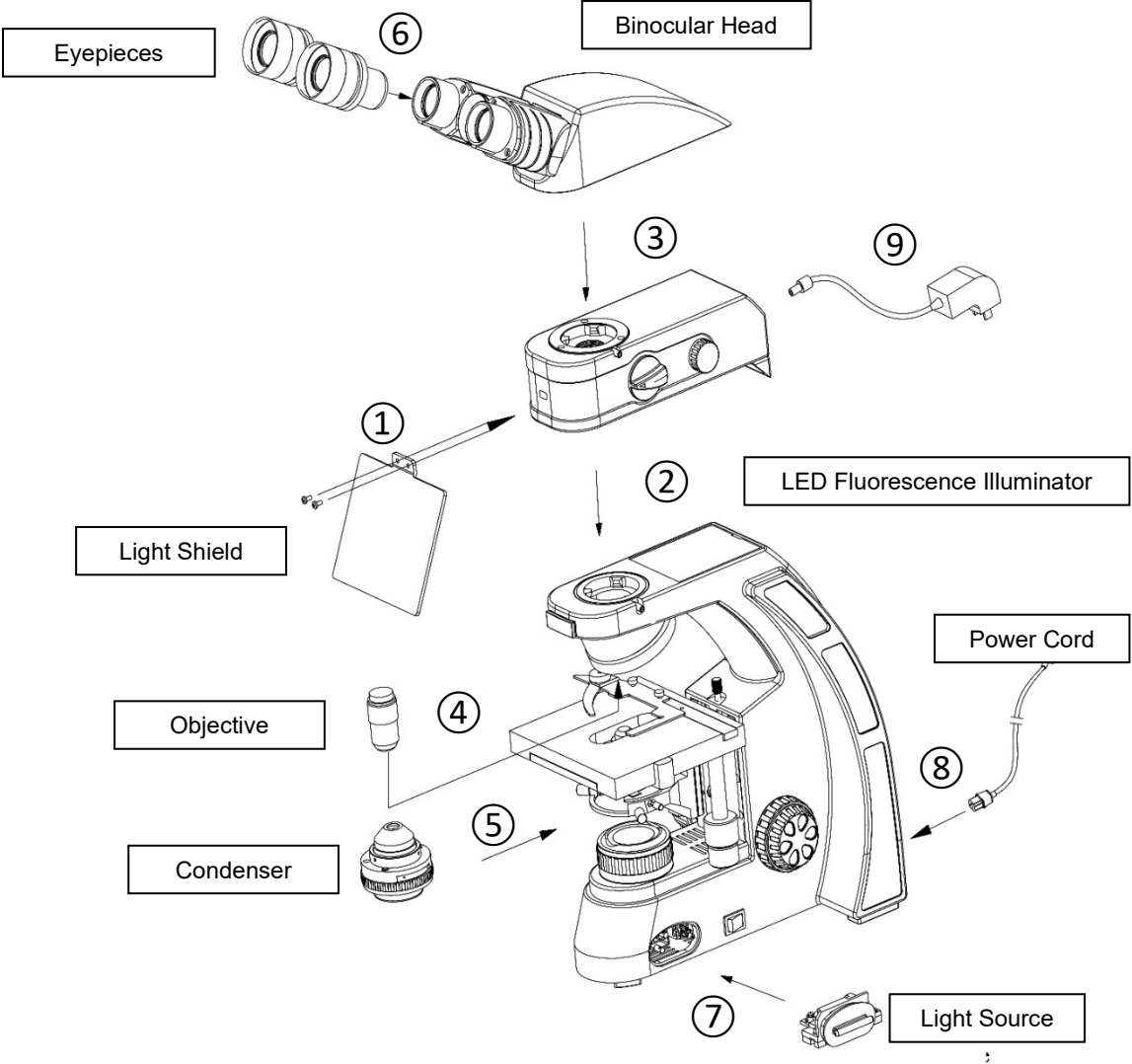
The diagram below shows how to assemble the various modules. The numbers indicate the order of assembly. Your microscope was preassembled by our factory technicians at our New York facility prior to shipment. Should you need to disassemble/assemble your microscope in the future, please follow the instructions outlined below.

When assembling the microscope, make sure that all parts are free of dust and dirt, and avoid scratching any parts or touching glass surfaces.

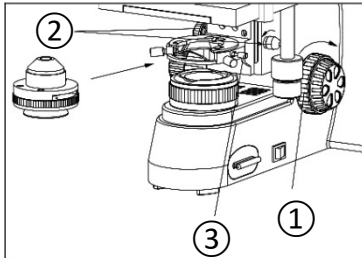


# ASSEMBLY DIAGRAM

## EXC-350-470 Fluorescence Microscope



**ASSEMBLY** *(continued)*



**Fig. 1**

**Condenser**

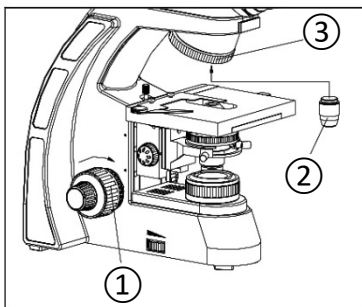
The condenser was installed and centered by our technicians prior to delivery. If the condenser needs to be re-installed or adjusted in the future, rotate the coarse focusing knob ① to raise the stage to the highest position (see Fig. 1).

Rotate the condenser up-down knob ② to lower the bracket of condenser to the suitable position.

Fully loosen the condenser lock-screw ③.

Insert the condenser into the hole of the stand according to the directional arrow, until the condenser is even with the stand, and then rotate the condenser to make sure the iris diaphragm control lever faces forward.

Tighten the lock-screw ③ of the condenser, then raise the condenser with the up-down knob to the highest position.

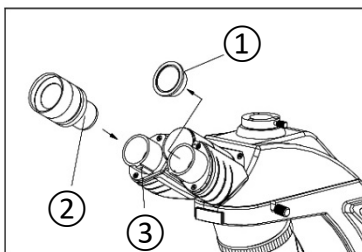


**Fig. 2**

**Objectives**

Rotate the coarse focusing knob ① to lower the stage to a suitable position (see Fig. 2).

Install the objectives into the objective nosepiece ② from the lowest magnification to the highest in a clockwise direction from the rear.



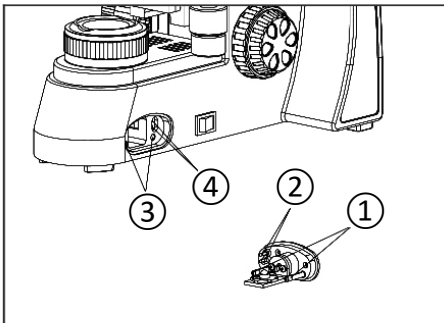
**Fig. 3**

**Eyepieces**

Remove the eyepiece caps ①.

Insert the eyepiece ② into the eyepiece tube ③ until it touches the surface of the eyepiece tube. Repeat above for the other eyepiece (see Fig. 3).

## ASSEMBLY *(continued)*

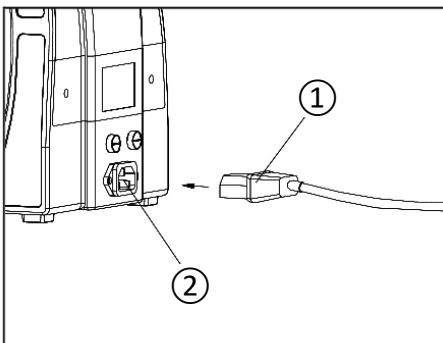


**Fig. 4**

### LED Illuminator

**IMPORTANT:** The LED illuminator bulb is pre-installed. These instructions are only necessary should the need arise for a replacement lamp.

Align the orientation pin ① and power pin ② on the light source to the oriented holder ③ and power socket ④, then push the light source in until it is flush (see Fig. 4).



**Fig. 5**

### Connecting the Power Cord

**IMPORTANT:** Use care when storing the power cord so that it does not bend or twist.

Make sure the power switch is at "0" (OFF) before connecting.

Insert the connector ① of power cord securely into the power socket ②, (see Fig. 5).

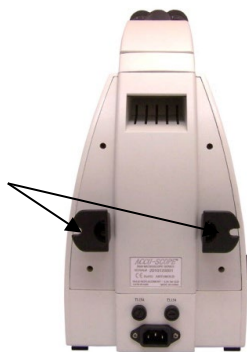
Insert the other connector securely into an electrical outlet.

The microscope uses a universal power supply so it may be used in any voltage range between 90 ~ 240v when used with the appropriate line cord.

*An optional cord hanger can be installed on your microscope for simple and easy storage. (see Photos 1 & 2)*

**Photo 1**

*Optional  
Cord Hanger*



**Photo 2**

*Optional  
Cord Hanger  
Shown  
With Cord*



## ADJUSTMENT & OPERATION

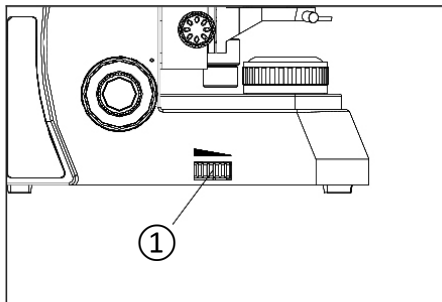


Fig. 6

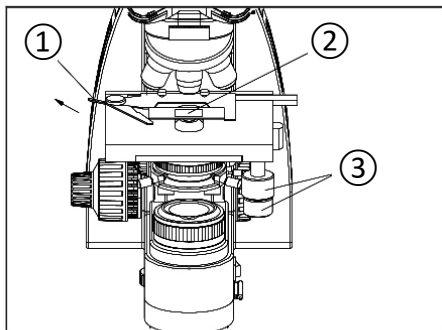


Fig. 7

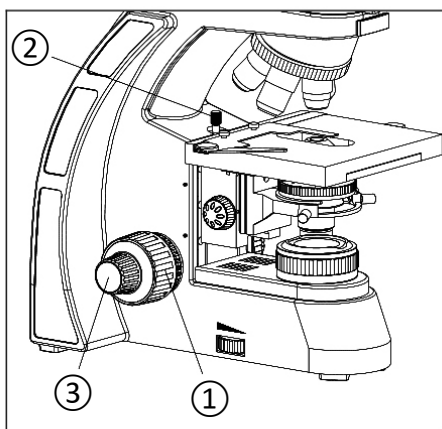


Fig. 8

### Illumination

With the microscope turned on, rotate the light adjustment knob ① until the illumination is comfortable for observation. Rotate the light adjustment knob clockwise to raise the voltage and brightness. Rotate the light adjustment knob counterclockwise to lower the voltage and brightness (see Fig. 6).

### Placing the Specimen Slide

Push the slide finger ① of the specimen holder backwards.

Place the slide ② into the slide holder with the cover glass facing up and release the slide finger so it closes and secures the slide in place.

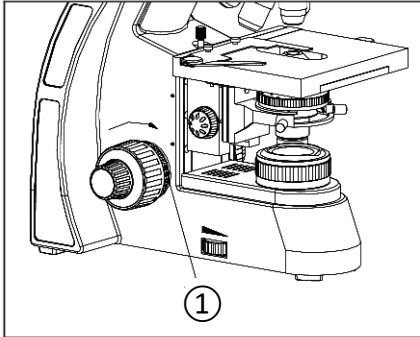
Rotate the X and Y-axis knobs ③ to move the slide into position. (Fig. 7)

### Adjusting the Focus

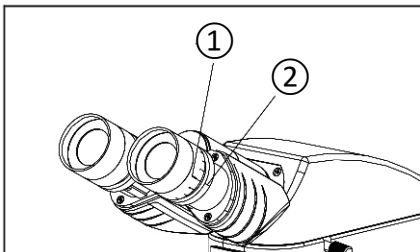
To ensure that you obtain sharp images with both eyes (since eyes vary, especially for those wearing glasses) any eyesight variation can be corrected in the following manner: set both diopter collars to "0". Using your left eye only and the 10X objective, focus your specimen by adjusting the coarse adjustment knob ①. When the image is in view, refine the image to its sharpest focus by turning the fine adjustment knob ②. Rotate the diopter collar to obtain the sharpest focus. To obtain the same sharp image using your right eye, do not touch the coarse or fine adjustments. Instead, rotate the right diopter collar until the sharpest image appears. Repeat several times to check.

**NOTE:** do not counter rotate the focusing knob as this will cause severe problems and damage to the focusing system. (Fig. 8)

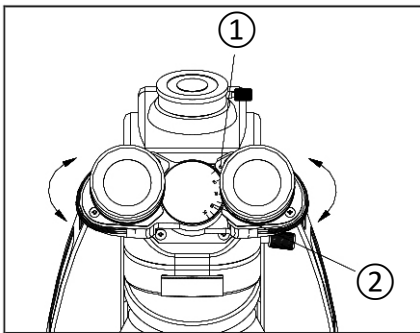
**ADJUSTMENT & OPERATION** *(continued)*



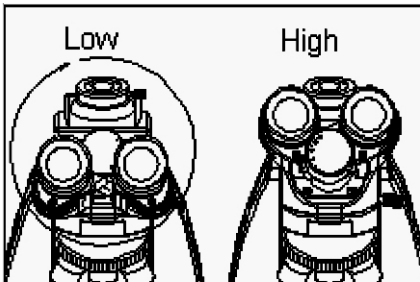
**Fig. 9**



**Fig. 10**



**Fig. 11**



**Fig. 12**

**Adjusting the Focusing Tension**

If the handle is very heavy when focusing or the specimen leaves the focus plane after focusing or the stage lowers by itself, please adjust the tension adjustment ring ①. Located on the left side of the stand between the coarse adjustment knob and the vertical arm is an adjustable tension control dial that is preset at our facility. This allows the user to adjust the coarse control tension to their individual preference. (Fig. 9).

**Adjusting the Diopter**

Set the diopter rings ① & ② of both eyepieces to “0” (zero) position. (Do this when users change, because different users will have different diopter settings.)

Place an easy-to-observe specimen on the stage plate, i.e., a coin. Looking only into the left eyepiece, adjust the diopter ring on left eyepiece to focus the specimen. Then repeat procedure for the right eyepiece. Different users will have different diopter settings, so adjust the diopter for each individual user. Be sure to make a note of your eye’s diopter setting should another user change the setting. (Fig. 10)

**Adjusting the Interpupillary Distance**

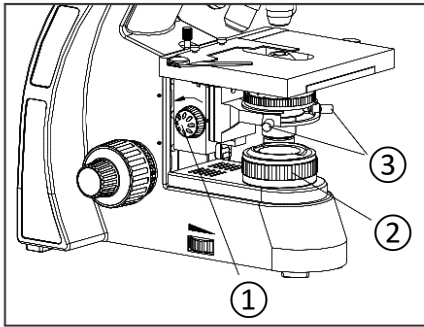
To adjust the interpupillary distance, hold the left and right eyetubes while observing a specimen. Rotate the eyetubes around the central axis until the fields of view of both eyetubes coincide completely. A complete circle should be seen in the viewing field when viewing the specimen slide. An improper adjustment will cause operator fatigue and will disrupt the objective parfocality.

Where “●” ① on the eyepiece tube lines up to the interpupillary scale ②, then that is the number for the interpupillary distance. Range: 50~75mm. (Fig. 11).

Remember your interpupillary for future operation.

**NOTE:** The eyepiece tubes can be rotated 180° to increase the eyepoint height by 34mm to accommodate the needs of different users. (Fig. 12)

## **ADJUSTMENT & OPERATION** *(continued)*



**Fig. 13**

### **Centering the Condenser**

Rotate the condenser knob ① to raise it to the highest position (Fig. 13).

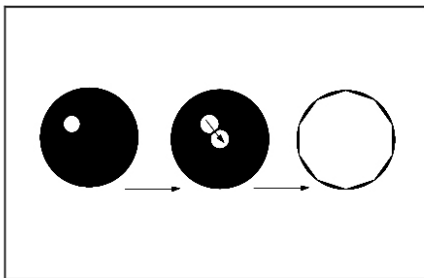
Rotate the 10x objective into the light path and focus the specimen.

Rotate the field iris diaphragm adjustment ring ② to put the field iris diaphragm to the smallest position.

Rotate the condenser knob and adjust the image to be its sharpest.

Adjust the center adjustment screws ③ and move the specimen to the center of the field of view (Fig. 14).

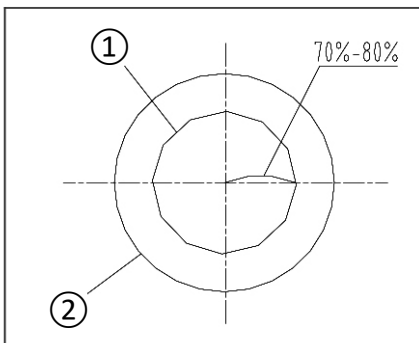
Open the field iris diaphragm gradually. If the image is in the center all the time and inscribed to the field of view, the condenser has been centered correctly.



**Fig. 14**

### **Adjusting the Field Iris Diaphragm**

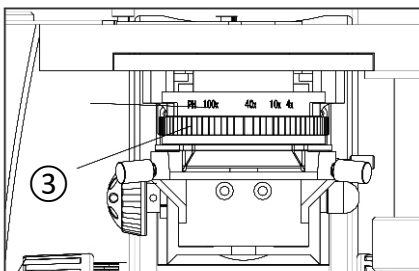
By limiting the diameter of the light entering the condenser, the field iris diaphragm can prevent other light and strengthen the image contrast. When the image is just on the edge of the field of view, the objective can show the best performance and obtain the clearest image (Fig. 15).



**Fig. 15**

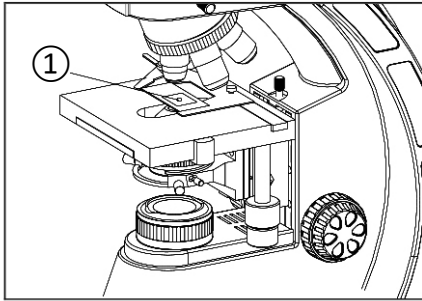
### **Adjusting the Aperture Diaphragm**

The aperture size is increased or decreased by rotating the condenser aperture diaphragm ring ③. When the aperture is closed, the brightness and resolution are decreased but the contrast and range of focus are increased. If the aperture diaphragm is opened, the brightness and resolution are increased; however, the contrast and range of focus are diminished. For optimal viewing conditions set the condenser aperture diaphragm lever to match the magnification of the objective in the optical path (Fig. 16).

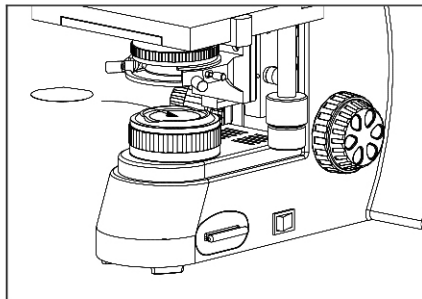


**Fig. 16**

## **ADJUSTMENT & OPERATION** *(continued)*



**Fig. 17**



**Fig. 18**

### **Using the Oil Objective (100x)**

The procedure for examining a specimen using an oil immersion objective is as follows:

Rotate the nosepiece so the low power objective is in the optical path.

Place one drop of immersion oil on the lighted area of the specimen slide ① (Fig 17). Dust or air bubbles in the oil can destroy the definition of the image. If the bubbles are trapped between the objective lens and the slide, clean off the oil and start again or try to eliminate the bubble by rotating the objective back and forth.

Rotate the nosepiece so the 100xR oil immersion objective is in the light path.

With your eye at the level of the stage, use the coarse focus knob to raise the stage with the specimen cover glass. When you see a flash of light at this location the objective lens has made contact with the immersion oil and the microscope can now be focused using the fine focus knob.

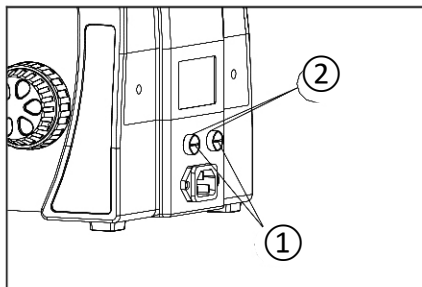
Each time you finish using the oil immersion objective wipe off all traces of oil from the objective and the specimen cover glass with a lens tissue or clean soft cloth. Cleaning after each use will prevent oil from contaminating the high dry objective (40xR) and degrading its optical performance, prevent dust and dirt from accumulating on the lens of the objective and degrading its optical performance, and will keep the slide clean to work with.

### **Using & Installing A Filter**

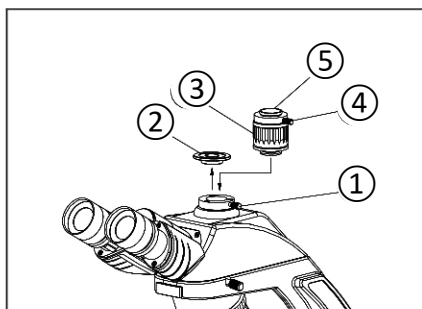
A filter is used to make the background color more suitable for the application and as a method to increase the contrast. (Fig. 18)

Filters are available in clear blue, frosted blue, green, yellow and white.

## ADJUSTMENT & OPERATION *(continued)*



**Fig. 19**



**Fig. 20**

### Replacing the Fuses

Turn the main switch to “0” (OFF) before replacing a fuse. Unplug the power cord from the microscope.

Screw off the fuse ① or ② from the fuse base with a Phillip’s head type screwdriver.

Install a new fuse and screw it on the fuse base (Fig. 19).

**Specification of the fuse: 250V, 3.15A.**  
CAT #350-3277-3

### Installation of a Camera Adapter

Loosen the lock screw ① on the trinocular head and remove the dust cap ② on the trinocular port.

Remove the dust caps of the C-mount adapter and insert the C-mount into the trinocular head as shown in Fig. 20.

Tighten the lock screw ①.

Loosen the lock screw ④ on the C-mount.

Remove the C-mount ⑤ from the lower portion of the adapter.

Screw onto the camera and then install assembled C-mount and camera back onto the lower assembly. Lock it in place by tightening the lock screw.

Observe the image through the eyepieces and bring it into focus.

Look at the camera image and adjust the focus of the camera image via the rotating ring ③ until it matches the focus as seen through the eyepieces.

## ADJUSTMENT & OPERATION *(continued)*

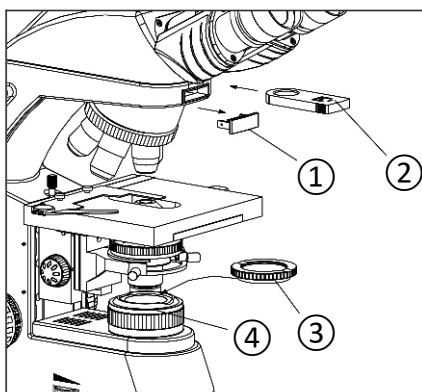


Fig. 21

### Simple Polarizing

Simple polarizing includes the analyzer ② and the polarizer ③. (Fig. 21)

#### INSTALLATION:

Unplug the analyzer dust cap from the arm ① and insert the analyzer face up .

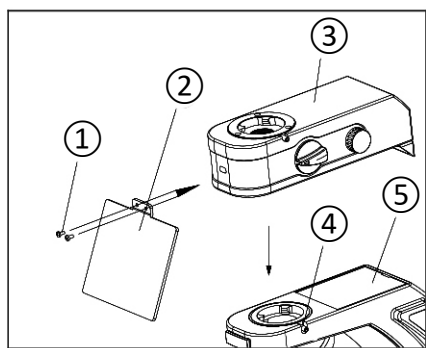
Place the polarizer in the groove on top of the field iris diaphragm as shown.

Rotation of the polarizer ④ will change the orthogonal status of polarization.

**NOTE:** When the image is darkest as you viewed through the eyepieces, polarization has been achieved.

# LED FLUORESCENCE ATTACHMENT *(Optional)*

## DETAILED ASSEMBLY & OPERATION



**Fig. 22**

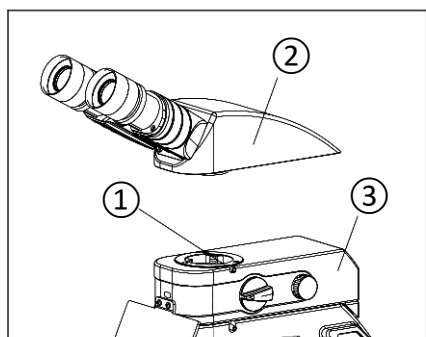
### Assembling the LED Fluorescence Illuminator

Attach the light shield ② on the LED fluorescence illuminator ③ with the screws ①.

Loosen the lock screw ④.

Match the dovetail on the bottom of the LED fluorescence illuminator ③ to the dovetail on the arm ⑤, and secure it by tightening the lock screw ④. (Fig. 22)

**NOTE: The light shield is used when observing in UV lighting.**



**Fig. 23**

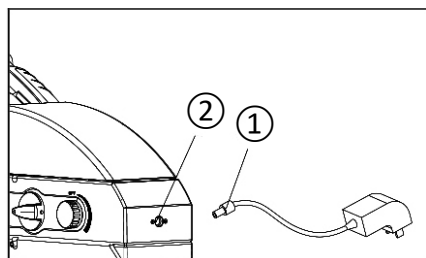
Loosen the lock screw ①.

Match the dovetail on the bottom of the head ② to the dovetail mount on the top of the illuminator ③, and secure it by tightening the lock screw ①. (Fig. 23)

## IMPORTANT

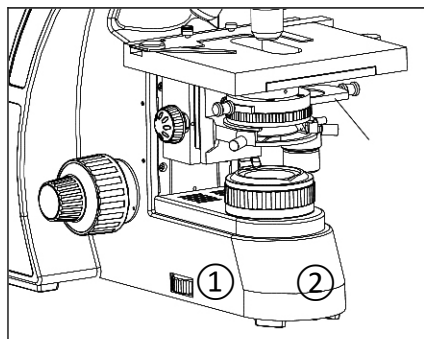
Before connecting the external transformer power supply, make sure the light adjustment knob is in the "OFF" position.

To connect the external transformer power supply, insert the one end of the transformer ① into the LED fluorescence illuminator socket ②. Insert the other end into an electrical outlet. (Fig. 24)

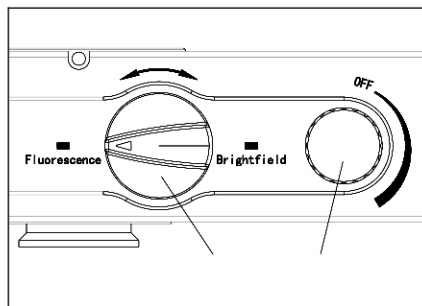


**Fig. 24**

**LED FLUORESCENCE ATTACHMENT (Optional)**  
**DETAILED ASSEMBLY & OPERATION - (Continued)**



**Fig. 25**



**Fig. 26**

**NOTE**

When observing with fluorescence light, the user should pull the filter slider ① to the left into the light path to block transmitted light from the light path.

When observing with transmitted light, the user should pull the filter slider ① to the right into the light path to allow transmitted light into the light path. (Fig. 25)

LED fluorescence filter block adjustment knob ① can be rotated 180° according to the arrow on the knob to switch between transmitted brightfield observation and LED fluorescence observation. (Fig. 25)

**Illumination**

**TO TURN ON:** Rotate the fluorescence light adjustment knob ② clockwise to turn on the LED fluorescence illuminator.

**TO INCREASE ILLUMINATION:** Rotate the fluorescence light adjustment knob clockwise to increase illumination.

**TO DECREASE ILLUMINATION:** Rotate the fluorescence light adjustment knob ② counter clockwise to decrease (darken) illumination.

**TO TURN OFF:** Rotate the fluorescence light adjustment knob ② counter clockwise to turn off illuminator.

**NOTE**

When you switch the LED fluorescence filter block adjustment knob to **FLUORESCENCE**, the indicator light on the front of the illuminator unit is **ON** (illuminator) and fluorescence observation is possible.

When the LED fluorescence filter block adjustment knob is turned to **BRIGHTFIELD**, the indicator light on the front of the illuminator unit is **OFF** and brightfield observation is possible.

## PHASE CONTRAST SYSTEMS

### Turret Phase Contrast (for microscopes equipped with a phase contrast turret condenser)

Installation of the Phase Contrast Turret System Components & Alignment of the Condenser to the Optic Axis of the Microscope

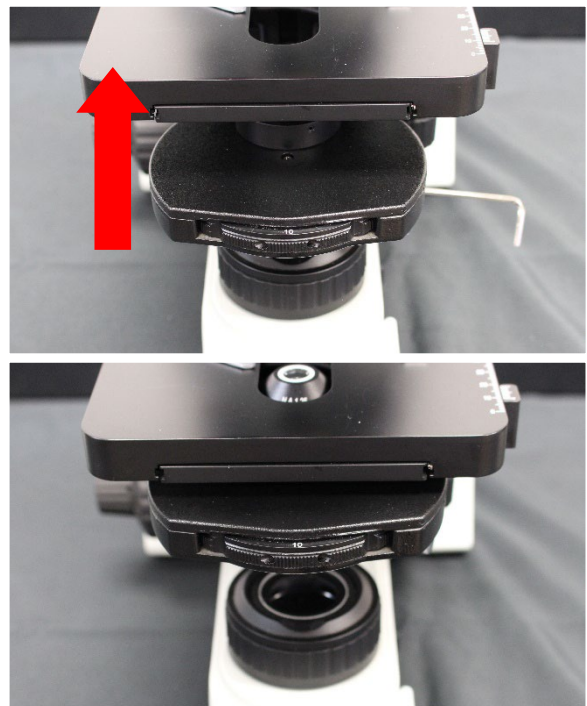
Prior to shipment your phase contrast set was assembled, aligned and tested at our distribution center in New York. The phase objectives and condenser were pre-centered and aligned by our technicians, however the phase annuli in the turret may require realignment after installation of the condenser.



### Phase Contrast Condenser

The phase contrast turret condenser for the EXC-350 may be pre-installed onto the microscope prior to shipping. If it is removed, it can easily be reinstalled. The mounting flange of the condenser housing has a registration pin. The condenser carrier has a matching alignment groove. Install the condenser so the registration pin slides into the alignment groove. After installation, alignment of the phase annuli in the condenser should be confirmed.

1. Mount the Phase Contrast objectives onto the nosepiece— clockwise lowest to highest magnification.
2. Install the Phase Contrast Turret-style N.A. 1.25 condenser onto the condenser carrier. Tighten the securing screw with the provided hex wrench. Raise the condenser position until the top lens is near the surface of the stage.



3. Position the condenser turret rotating plate to the "BF" position.

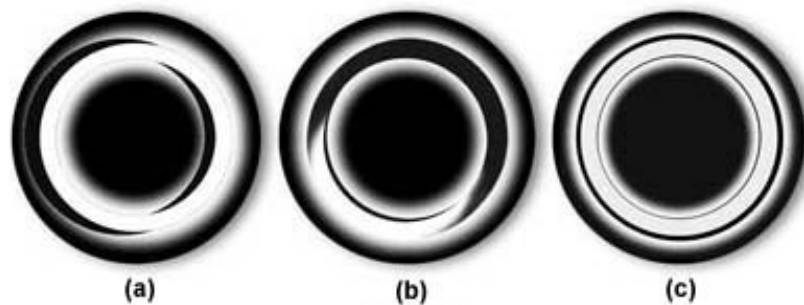


4. Center the condenser. Refer to the section "Centering the Condenser" on Page 13 of this manual for steps and illustrations.
5. With the 10x objective in the light path, Replace the "stained slide" with a phase contrast specimen (for example, a fresh "cheek cell" preparation).
6. Remove one eyepiece and install the supplied centering telescope ("CT" in the photo to the right). Focus the telescope on the phase ring inside the 10x Phase Contrast objective.



7. Rotate the condenser-turret to the "10" position. As you observe through the telescope you will see two different rings, See illustration below.

### Phase Plate and Light Annulus Alignment



8. The condenser-turret has two adjusting screws. These are used to align annular light rings in the condenser-turret to the corresponding phase ring in the objectives. Insert the provided adjustment screwdrivers into the holes for the adjustment screws. The correct holes are located toward the back of the condenser.

**Note the incorrect placement indicated by the red "X". The 3<sup>rd</sup> photo to the right shows a close-up of an insertion hole for the adjustment screwdriver.**

Turn the screwdrivers to move the 10 annulus so that it is aligned – see (c) in the above illustration. Remove the alignment screwdrivers when finished.



9. Repeat the above annulus alignment procedure for the remaining Phase objectives on the microscope. Be sure to change the phase turret to the position that matches the objective (i.e. 20 for 20x, 40 for 40x).

**NOTE: You MUST remove the alignment screwdrivers from the turret condenser prior to rotating the turret.**

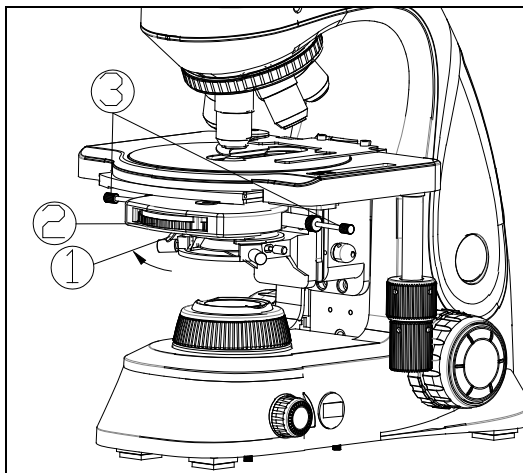
Return the adjustment screwdrivers to storage for safe keeping and future use.

## 10. Green Filter

To use the green filter (may aid in adding contrast), set the filter on top of the illuminator housing.



## Phase Contrast & Darkfield Condenser (optional)



If you ordered your microscope with turret phase contrast with darkfield, your microscope should arrive with the turret phase contrast/darkfield condenser already installed, and the phase and darkfield annuli were pre-centered at our factory.

Rotate the phase contrast ring<sup>②</sup> to “BF” position for brightfield observation. When it sounds “ka-da” in rotating, it indicates that one diaphragm or hole is rotated into the center of optical path.

For phase contrast or darkfield (DF) observation, rotate a phase contrast objective into the optical path. Then rotate the condenser turret into the position with the corresponding objective magnification. NOTE: Ensure that the condenser diaphragm is wide open (“PH” position).

For darkfield observation, rotate the condenser turret to the “DF” position. Turn an appropriate objective into the light path. Darkfield contrast works using objectives with Numerical Apertures (NA) of 0.65 or below. In most cases, this includes 4x, 10x, 20x and 40x Plan Achromat objectives. Confirm the NA on the barrel of your objectives – it is indicated after the magnification followed by a “/”.

## Slider Phase Contrast (for microscopes equipped with phase contrast slider system)

Installation of the Phase Contrast Slider System Components & Alignment of the Condenser to the Optic Axis of the Microscope

Prior to shipment your phase contrast set was assembled, aligned and tested at our distribution center in New York. The phase slider objectives and condenser were pre-centered and aligned by our technicians.

**IMPORTANT:** Before you can use the phase slider, you must remove the dust shield cover from the condenser housing and install the phase annuli slider in its place.



### Phase Contrast Condenser – Slider Type

The slider-type phase contrast condenser for the EXC-350 is pre-installed onto the microscope. If it is removed, it can easily be reinstalled without the need to realign the phase annuli to the phase ring in each corresponding phase contrast objective. The mounting flange of the condenser housing has a registration pin. The condenser carrier has a matching alignment groove. Install the condenser so the registration pin slides into the alignment groove.



**NOTE:** The slight angle of the slider is intentional. It allows clearance for full travel of the slider plate between the <-10 BF 40-> phase annulus positions.

### Removing the Dust Shield Cover

Slide the dust shield cover out from the condenser housing (FIG. 1). Be sure to keep it to reinstall it should you need to transport the microscope. FIG. 2 shows the condenser housing with the dust shield cover removed.



## Installing the Phase Slider

Before inserting the Phase slider, it is recommended the iris diaphragm lever be set to PH on the condenser.

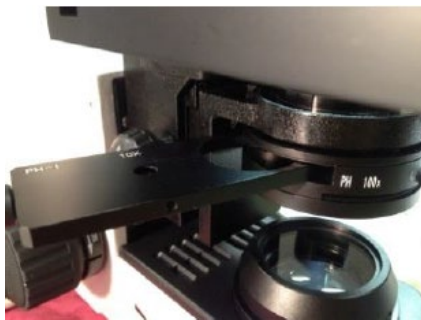
Insert the slider into the slot on the condenser as shown in FIG. 3 & FIG 4.

Move the slider to its position that corresponds to the phase objective in use (i.e., 40x objective = 40x position on slider).

Raise the condenser to its highest position.

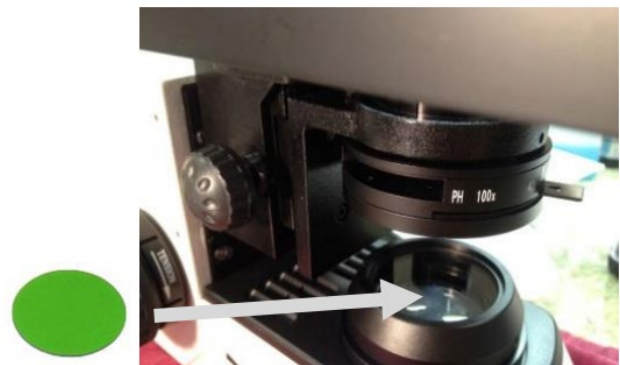
Refer to the instruction manual provided with the microscope on how to focus on a specimen.

Condenser Height Adjustment Knob



## Green Filter

To use the green filter (may aid in adding contrast), set the filter on top of the illuminator housing.



## TROUBLESHOOTING

Under certain conditions, performance of this unit may be adversely affected by factors other than defects. If a problem occurs, please review the following list and take remedial action as needed. If you cannot solve the problem after checking the entire list, please contact your local dealer for assistance.

### OPTICAL

Problem	Cause	Corrective Measure
Darkness at the periphery or uneven brightness of view field	Revolving nosepiece not in click stop position	Revolve the nosepiece to click stop position by swinging the objective correctly into the optical path
Dirt or dust on the view field	Dirt or dust on the lens - eyepiece, condenser, objective, collector lens or specimen	Clean the lens
Poor image quality	<p>No cover glass attached to the slide</p> <p>Cover glass is too thick or thin</p> <p>Slide maybe upside down</p> <p>Immersion oil is on a dry objective (especially the 40xR)</p> <p>No immersion oil used with 100xR objective</p> <p>Air bubbles in immersion oil</p> <p>Condenser aperture is closed or open too much</p> <p>Condenser is positioned too low</p>	<p>Attach a 0.17mm cover glass</p> <p>Use a cover glass of the appropriate thickness (0.17mm)</p> <p>Turn slide over so the cover glass faces up</p> <p>Check the objectives, clean if necessary</p> <p>Use immersion oil</p> <p>Remove bubbles</p> <p>Open or close properly</p> <p>Position the condenser slightly lower than the upper limit</p>

**IMAGE PROBLEMS**

<b>Problem</b>	<b>Cause</b>	<b>Corrective Measures</b>
Image moves while focusing	Specimen rises from stage surface  Revolving nosepiece is not in the click-stop position	Secure the specimen in the slide holder  Revolve the nosepiece to the click-stop position
Image tinged yellow	Lamp intensity is too low  Blue filter not used	Adjust the light intensity by rotating the intensity control dial and/or iris diaphragm  Use daylight blue filter
Image is too bright	Lamp intensity is too high	Adjust the light intensity by rotating the intensity control dial and/or iris diaphragm
Insufficient brightness	Lamp intensity is too low  Aperture diaphragm closed too far  Condenser position too low	Adjust the light intensity by rotating the intensity control dial and/or iris diaphragm  Open to the proper setting  Position the condenser slightly lower than the upper limit

**MECHANICAL PROBLEMS**

Image will not focus with high power objectives	Slide upside down  Cover glass is too thick	Turn the slide over so the cover glass faces up  Use a 0.17mm cover glass
High power objective contacts slide when changed from low power objective	Slide upside down  Cover glass is too thick  Diopter adjustment is not set properly	Turn the slide over so the cover glass faces up  Use a 0.17mm cover glass  Readjust the diopter settings as outlined in section 4.3

**MECHANICAL PROBLEMS** *(continued)*

<b>Problem</b>	<b>Cause</b>	<b>Corrective Measures</b>
Lamp does not light when switched on	No electrical power	Check power cord connection
	Lamp bulb burnt out	Replace bulb
	Fuse blown out	Replace fuse
Slippage of focus when using the coarse focusing knob	Tension adjustment is set too low	Increase the tension on the focusing knobs
Fine focus is ineffective	Tension adjustment is set too high	Loosen the tension on the focusing knobs

## MAINTENANCE

Please remember to **never** leave the microscope with any of the objectives or eyepieces removed and always protect the microscope with the dust cover when not in use.

## SERVICE

ACCU-SCOPE® microscopes are precision instruments which require periodic servicing to keep them performing properly and to compensate for normal wear. A regular schedule of preventative maintenance by qualified personnel is highly recommended. Your authorized ACCU-SCOPE® distributor can arrange for this service. Should unexpected problems be experienced with your instrument, proceed as follows:

1. Contact the ACCU-SCOPE® distributor from whom you purchased the microscope. Some problems can be resolved simply over the telephone.

2. If it is determined that the microscope should be returned to your ACCU-SCOPE® distributor or to ACCU-SCOPE® for warranty repair, pack the instrument in its original Styrofoam shipping carton. If you no longer have this carton, pack the microscope in a crush-resistant carton with a minimum of three inches of a shock absorbing material surrounding it to prevent in-transit damage. The microscope should be wrapped in a plastic bag to prevent Styrofoam dust from damaging the microscope. Always ship the microscope in an upright position; **NEVER SHIP A MICROSCOPE ON ITS SIDE**. The microscope or component should be shipped prepaid and insured.

### LIMITED MICROSCOPE WARRANTY

This microscope and its electronic components are warranted to be free from defects in material and workmanship for a period of five years from the date of invoice to the original (end user) purchaser. The LED lamp is warranted for a period of two years from the date of invoice to the original (end user) purchaser. This warranty does not cover damage caused in-transit, misuse, neglect, abuse or damage resulting from improper servicing or modification by other than ACCU-SCOPE approved service personnel. This warranty does not cover any routine maintenance work or any other work, which is reasonably expected to be performed by the purchaser. Normal wear is excluded from this warranty. No responsibility is assumed for unsatisfactory operating performance due to environmental conditions such as humidity, dust, corrosive chemicals, deposition of oil or other foreign matter, spillage or other conditions beyond the control of ACCU-SCOPE INC. This warranty expressly excludes any liability by ACCU-SCOPE INC. for consequential loss or damage on any grounds, such as (but not limited to) the non-availability to the End User of the product(s) under warranty or the need to repair work processes. Should any defect in material, workmanship or electronic component occur under this warranty contact your ACCU-SCOPE distributor or ACCU-SCOPE at (631) 864-1000. This warranty is limited to the continental United States of America. All items returned for warranty repair must be sent freight prepaid and insured to ACCU-SCOPE INC., 73 Mall Drive, Commack, NY 11725 – USA. All warranty repairs will be returned freight prepaid to any destination within the continental United States of America, for all foreign warranty repairs return freight charges are the responsibility of the individual/company who returned the merchandise for repair.

ACCU-SCOPE is a registered trademark of ACCU-SCOPE INC., Commack, NY 11725