



ACCU-SCOPE®

MANUAL

EXI-410
INVERTED
MICROSCOPE SERIES



CONTENTS

SAFETY NOTES	2
CARE AND MAINTENANCE	3
INTRODUCTION	3
UNPACKING AND COMPONENTS	3
COMPONENT DIAGRAMS	4
MICROSCOPE DIMENSIONS.....	10
ASSEMBLY DIAGRAM.....	11
DETAILED ASSEMBLY	12
CAMERA INSTALLATION (optional).....	14
MONITOR MOUNT INSTALLATION (optional)	14
FILTER CUBES INSTALLATION.....	15
OPERATION	
POWERING ON THE MICROSCOPE.....	18
ILLUMINATION.....	18
INTERPUPILLARY DISTANCE	18
FOCUSING	19
ADJUSTABLE TENSION CONTROL	20
STAGE PLATES (<i>OPTIONAL</i>)	20
SELECTING THE LIGHT PATH.....	21
APERTURE DIAPHRAGM ADJUSTMENT	21
PHASE CONTRAST OBSERVATION.....	22
PHASE CONTRAST SLIDER.....	22
CENTERING THE LIGHT USING ANNULUS	22
EMBOSS CONTRAST	23
USING A MICROSCOPY CAMERA (<i>OPTIONAL</i>)	24
USING FLUORESCENCE (<i>OPTIONAL</i>)	25
TROUBLESHOOTING.....	27
MAINTENANCE.....	30
SERVICE.....	30
WARRANTY	30

SAFETY NOTES

1. Open the shipping carton carefully to prevent any accessory, i.e. objectives or eyepieces, from dropping and being damaged.
2. Do not discard the molded shipping carton; the container should be retained should the microscope ever require reshipment.
3. Keep the instrument out of direct sunlight, high temperature or humidity, and dusty environments. Ensure the microscope is located on a smooth, level and firm surface.
4. If any specimen solutions or other liquids splash onto the stage, objective or any other component, immediately disconnect the power cord and wipe up the spillage. Otherwise, the instrument may be damaged.
5. All electrical connectors (power cord) should be inserted into an electrical surge suppressor to prevent damage due to voltage fluctuations.
6. Avoid blocking the natural air circulation for cooling. Ensure objects and obstructions are at least 10 centimeters from all sides of the microscope (the only exception is the table on which the microscope sits).
7. For safety when replacing the LED lamp or fuse, be sure the main switch is off ("O"), remove the power cord, and replace the LED bulb after the bulb and the lamp house has completely cooled.
8. Confirm that the input voltage indicated on your microscope corresponds to your line voltage. The use of a different input voltage other than indicated will cause severe damage to the microscope.
9. When carrying this product, firmly grasp the microscope with one hand in the recess in the lower front of the main body and the other hand in the recess in the rear of the main body. Refer to the figure below.

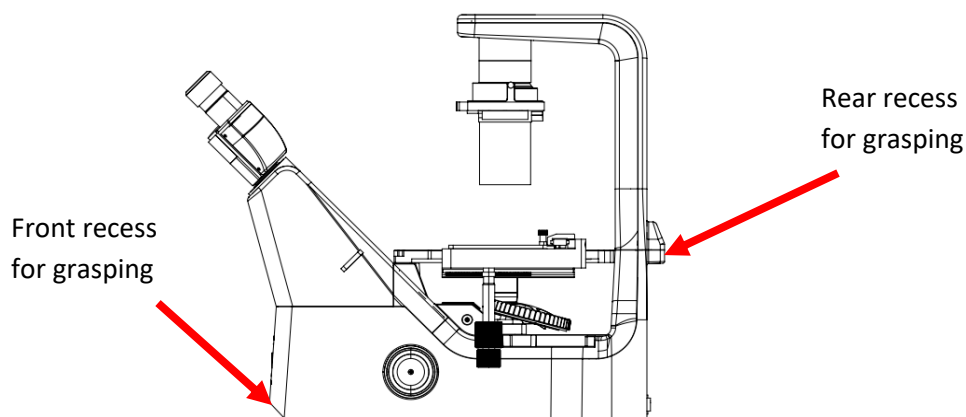

★ Do not grasp or hold using any other parts (such as the illumination pillar, focus knobs, eyetubes or stage) when carrying the microscope. Doing so may result in dropping the unit, damage to the microscope or failure of proper operation.

CARE AND MAINTENANCE

1. Do not attempt to disassemble any component including eyepieces, objectives or focusing assembly.
2. Keep the instrument clean; remove dirt and debris regularly. Accumulated dirt on metal surfaces should be cleaned with a damp cloth. More persistent dirt should be removed using a mild soap solution. Do not use organic solvents for cleansing.
3. The outer surface of the optics should be inspected and cleaned periodically using an air stream from an air bulb. If dirt remains on the optical surface, use a soft cloth or cotton swab dampened with a lens cleaning solution (available at camera stores). All optical lenses should be swabbed using a circular motion. A small amount of absorbent cotton wound on the end of a tapered stick such as cotton swabs or Q-tips, makes a useful tool for cleaning recessed optical surfaces. Avoid using an excessive amount of solvents as this may cause problems with optical coatings or cemented optics or the flowing solvent may pick up grease making cleaning more difficult. Oil immersion objectives should be cleaned immediately after use by removing the oil with lens tissue or a clean, soft cloth.
4. Store the instrument in a cool, dry environment. Cover the microscope with the dust cover when not in use.
5. ACCU-SCOPE® microscopes are precision instruments which require periodic preventative maintenance to maintain proper performance and to compensate for normal wear. An annual schedule of preventative maintenance by qualified personnel is highly recommended. Your authorized ACCU-SCOPE® distributor can arrange for this service.

INTRODUCTION

Congratulations on the purchase of your new ACCU-SCOPE® microscope. ACCU-SCOPE® microscopes are engineered and manufactured to the highest quality standards. Your microscope will last a lifetime if used and maintained properly. ACCU-SCOPE® microscopes are carefully assembled, inspected and tested by our staff of trained technicians in our New York facility. Careful quality control procedures ensure each microscope is of the highest quality prior to shipment.

UNPACKING AND COMPONENTS

Your microscope arrived packed in a molded shipping carton. ***Do not discard the carton:*** the carton should be retained for reshipment of your microscope if needed. Avoid placing the microscope in dusty surroundings or in high temperature or humid areas as mold and mildew will form. Carefully remove the microscope from the EPE foam container by its arm and base and place the microscope on a flat, vibration-free surface. Check the components against the following standard configuration list:

1. Stand, which includes the supporting arm, focusing mechanism, nosepiece, mechanical stage (optional), condenser with iris diaphragm, illumination system, and phase contrast accessories (optional).
2. Binocular viewing head
3. Eyepieces as ordered
4. Objectives as ordered
5. Stage plate inserts, green and yellow filters (optional)
6. Dust cover
7. 3-prong electric power cord
8. Camera adapters (optional)
9. Fluorescence filter cubes (optional)

Optional accessories such as optional objectives and/or eyepieces, slides sets, etc., are not shipped as part of the standard equipment. These items, if ordered, are shipped separately.

COMPONENTS DIAGRAMS

EXI-410 (with Phase Contrast)

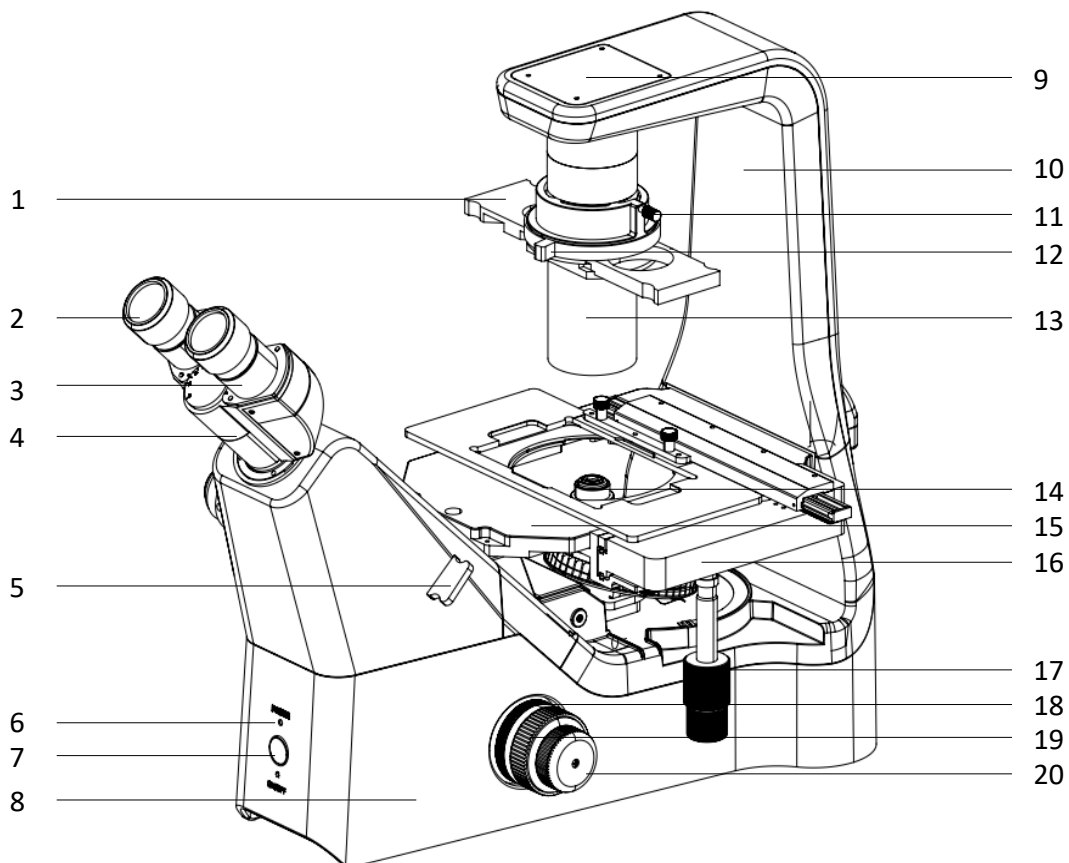

- | | |
|---------------------------|--|
| 1. Phase Contrast Slider | 12. Field Iris Diaphragm |
| 2. Eyepiece | 13. Condenser |
| 3. Eyetube | 14. Objective |
| 4. Viewing Head | 15. Stage |
| 5. Emboss Contrast Slider | 16. Mechanical Stage with Universal Holder
(optional) |
| 6. Power Indicator | 17. Mechanical Stage Control Knobs (XY
movement) |
| 7. Illumination Selector | 18. Focus Tension Adjustment Collar |
| 8. Main Frame | 19. Coarse Focus |
| 9. LED Lamp (transmitted) | 20. Fine Focus |
| 10. Illumination Pillar | |
| 11. Condenser Set Screw | |

EXI-410 INVERTED MICROSCOPE SERIES

EXI-410 (with Phase Contrast)

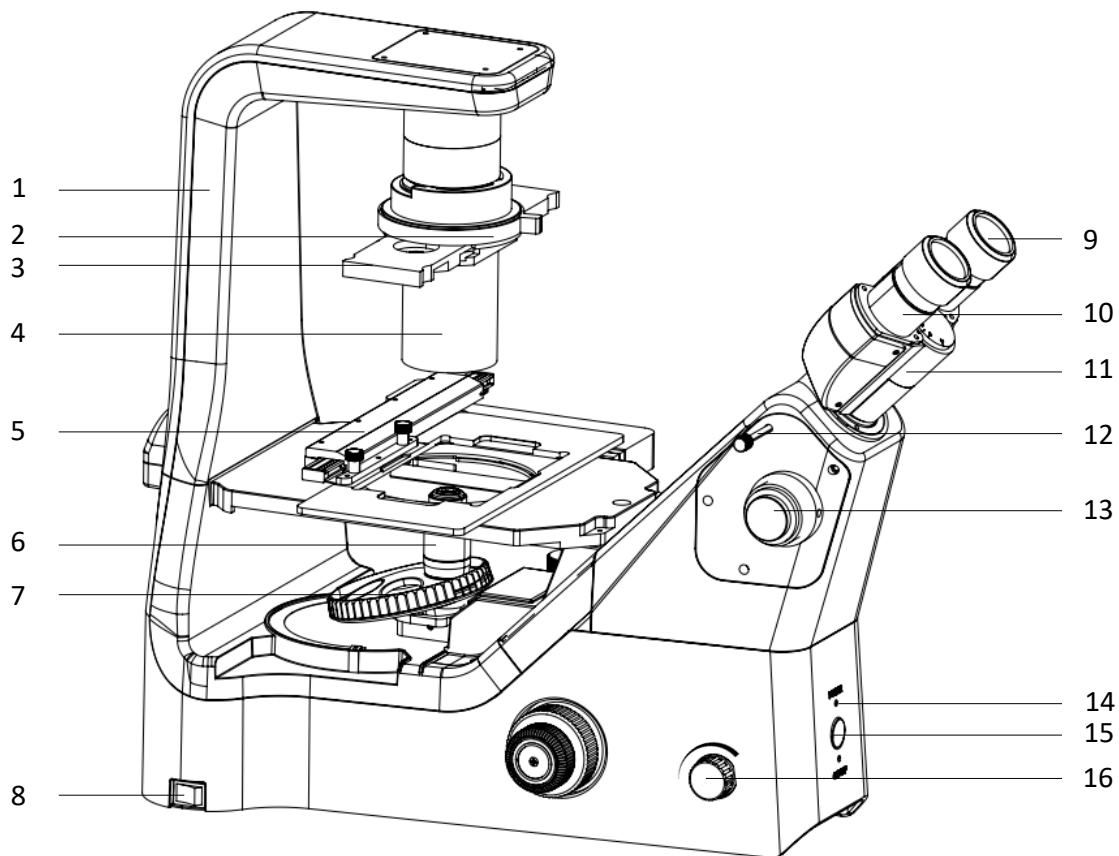

1. Illumination Pillar
2. Field Iris Diaphragm
3. Phase Contrast Slider
4. Condenser
5. Mechanical Stage with Universal Holder (optional)
6. Objective
7. Nosepiece
8. Power Switch

9. Eyepiece
10. Eyetube
11. Viewing Head
12. Light Path Selector
13. Camera Port
14. Power Indicator
15. Illumination Selector
16. Illumination Intensity Adjustment Knob

EXI-410 INVERTED MICROSCOPE SERIES

EXI-410 (with Phase Contrast)

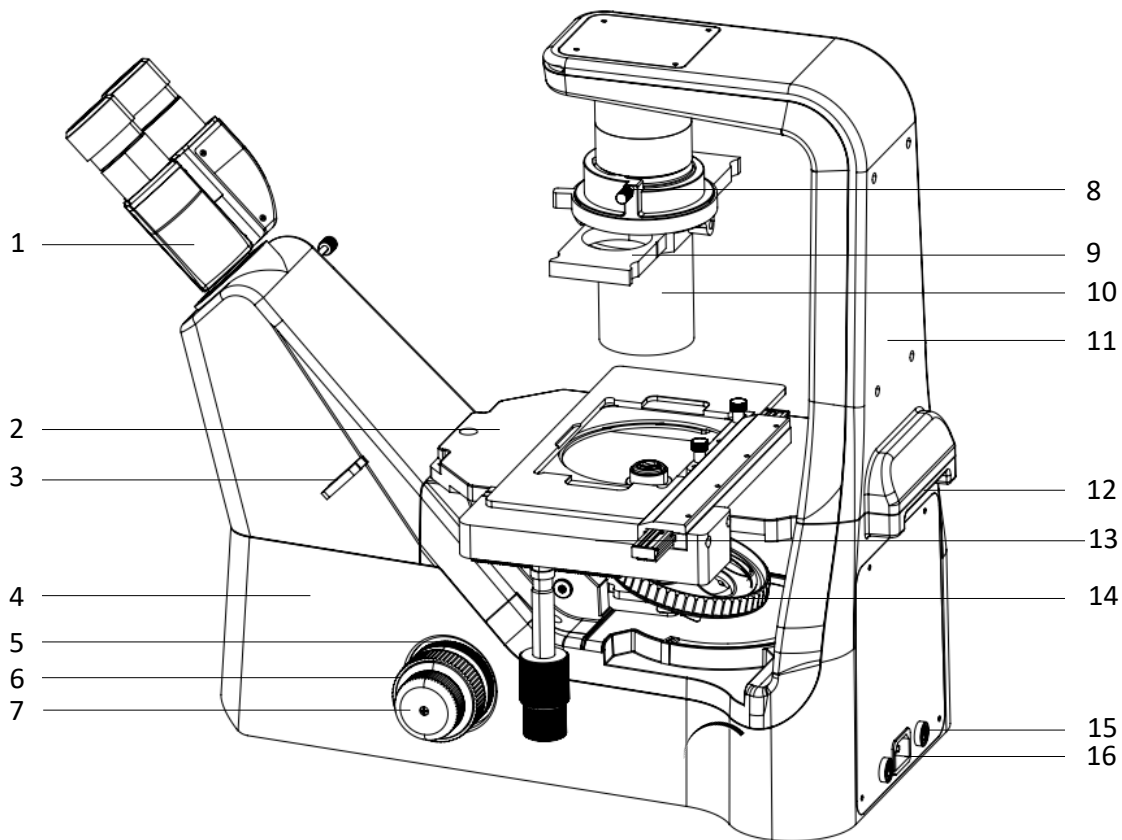

- | | |
|------------------------------------|---------------------------------|
| 1. Viewing Head | 9. Phase Contrast Slider |
| 2. Stage | 10. Condenser |
| 3. Emboss Contrast Slider | 11. Illumination Pillar |
| 4. Main Frame | 12. Rear Hand Grasp |
| 5. Focus Tension Adjustment Collar | 13. Mechanical Stage (optional) |
| 6. Coarse Focus | 14. Nosepiece |
| 7. Fine Focus | 15. Fuse |
| 8. Condenser Set Screw | 16. Power Outlet |

EXI-410 INVERTED MICROSCOPE SERIES

EXI-410-FL

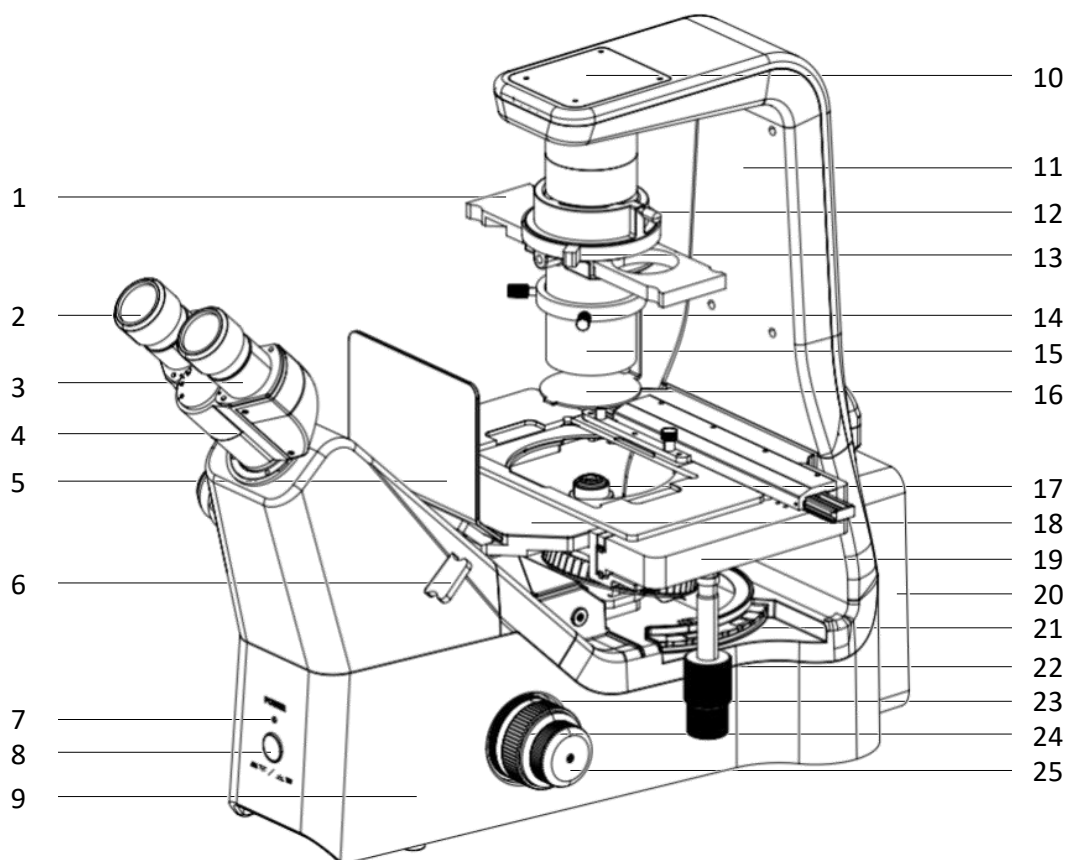

- | | |
|------------------------------|--|
| 1. Phase Contrast Slider | 14. Condenser Centering Screw |
| 2. Eyepiece | 15. Condenser |
| 3. Eyetube | 16. Light Shield |
| 4. Viewing Head | 17. Objective |
| 5. Fluorescence Light Shield | 18. Stage |
| 6. Emboss Contrast Slider | 19. Mechanical Stage with Universal Holder
(optional) |
| 7. Power Indicator | 20. Fluorescence Illumination |
| 8. Illumination Selector | 21. Fluorescence Turret |
| 9. Main Frame | 22. Mechanical Stage Control Knobs (XY
movement) |
| 10. LED Lamp (transmitted) | 23. Tension Adjustment Collar |
| 11. Illumination Pillar | 24. Coarse Focus |
| 12. Condenser Set Screw | 25. Fine Focus |
| 13. Field Iris Diaphragm | |

EXI-410 INVERTED MICROSCOPE SERIES

EXI-410-FL

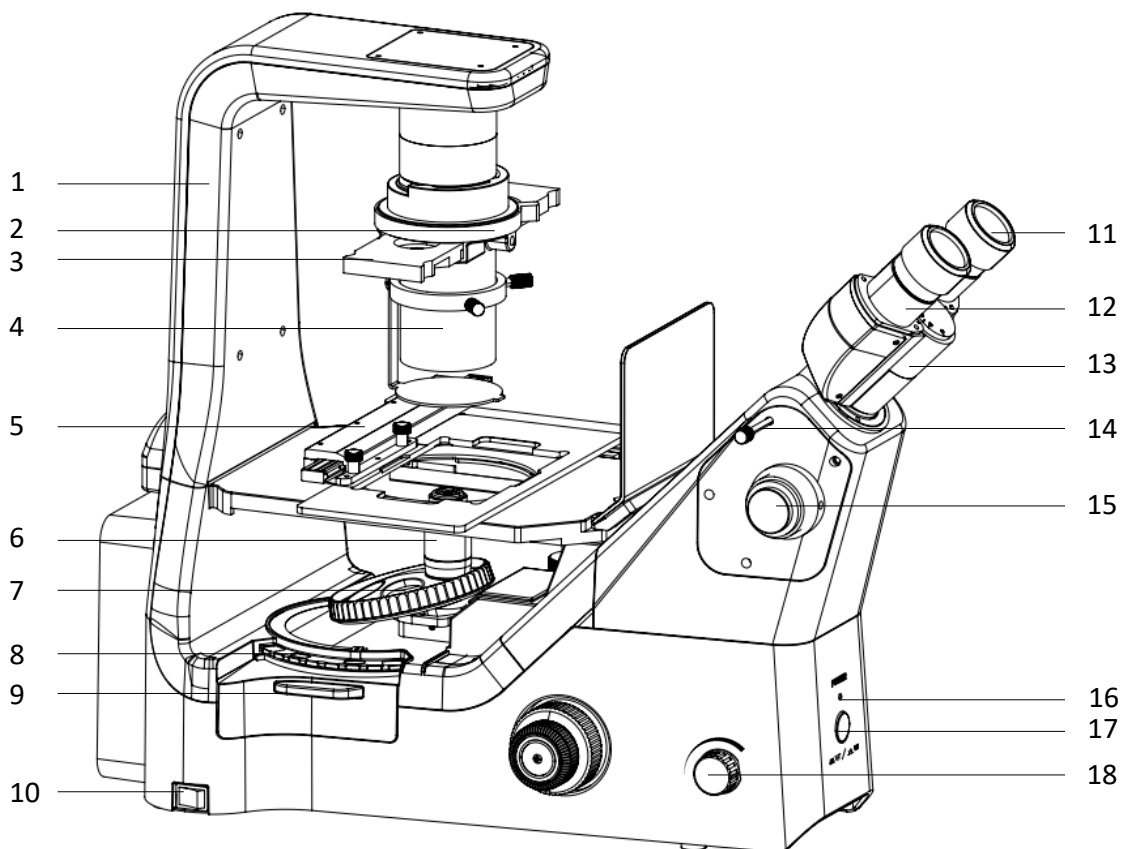

- | | |
|--|--|
| 1. Illumination Pillar | 10. Power Switch |
| 2. Field Iris Diaphragm | 11. Eyepiece |
| 3. Phase Contrast Slider | 12. Eyetube |
| 4. Condenser | 13. Viewing Head |
| 5. Mechanical Stage with Universal Holder (optional) | 14. Light Path Selector (Eyepieces/Camera) |
| 6. Objective | 15. Camera Port |
| 7. Nosepiece | 16. Power Indicator |
| 8. Fluorescence Turret | 17. Illumination Selector |
| 9. Fluorescence Turret Access Door | 18. Illumination Intensity Adjustment Knob |

EXI-410 INVERTED MICROSCOPE SERIES

EXI-410-FL

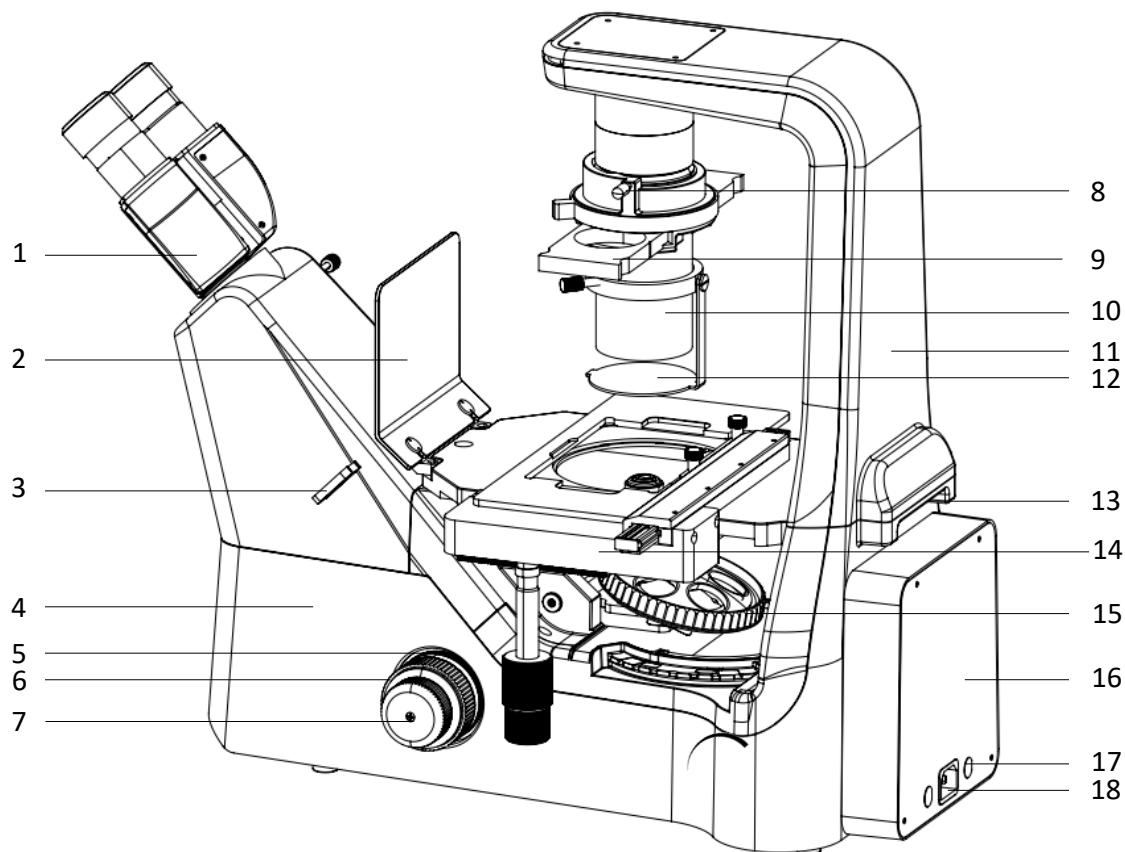

- | | |
|------------------------------------|-----------------------------------|
| 1. Viewing Head | 10. Condenser |
| 2. Fluorescence Light Shield | 11. Illumination Pillar |
| 3. Emboss Contrast Slider | 12. Light Shield |
| 4. Main Frame | 13. Rear Hand Grasp |
| 5. Focus Tension Adjustment Collar | 14. Mechanical Stage (optional) |
| 6. Coarse Focus | 15. Nosepiece |
| 7. Fine Focus | 16. LED Fluorescence Light Source |
| 8. Condenser Set Screw | 17. Fuse |
| 9. Phase Contrast Slider | 18. Power Outlet |

MICROSCOPE DIMENSIONS

EXI-410 Phase Contrast and Brightfield

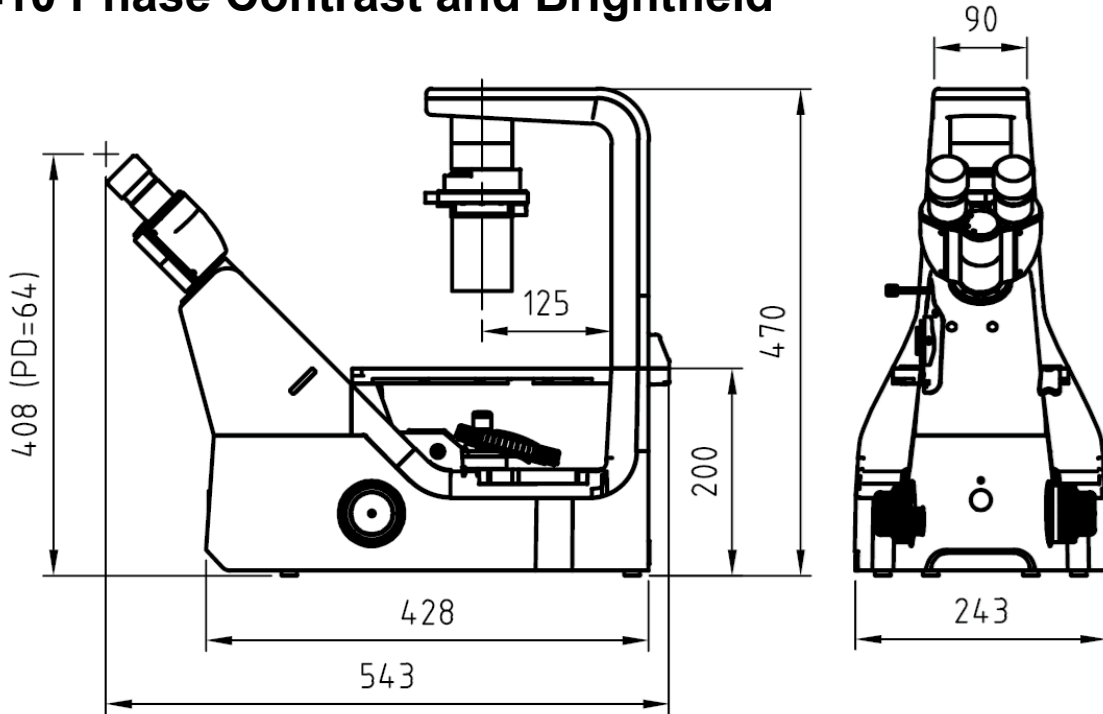

EXI-410-FL with Mechanical Stage

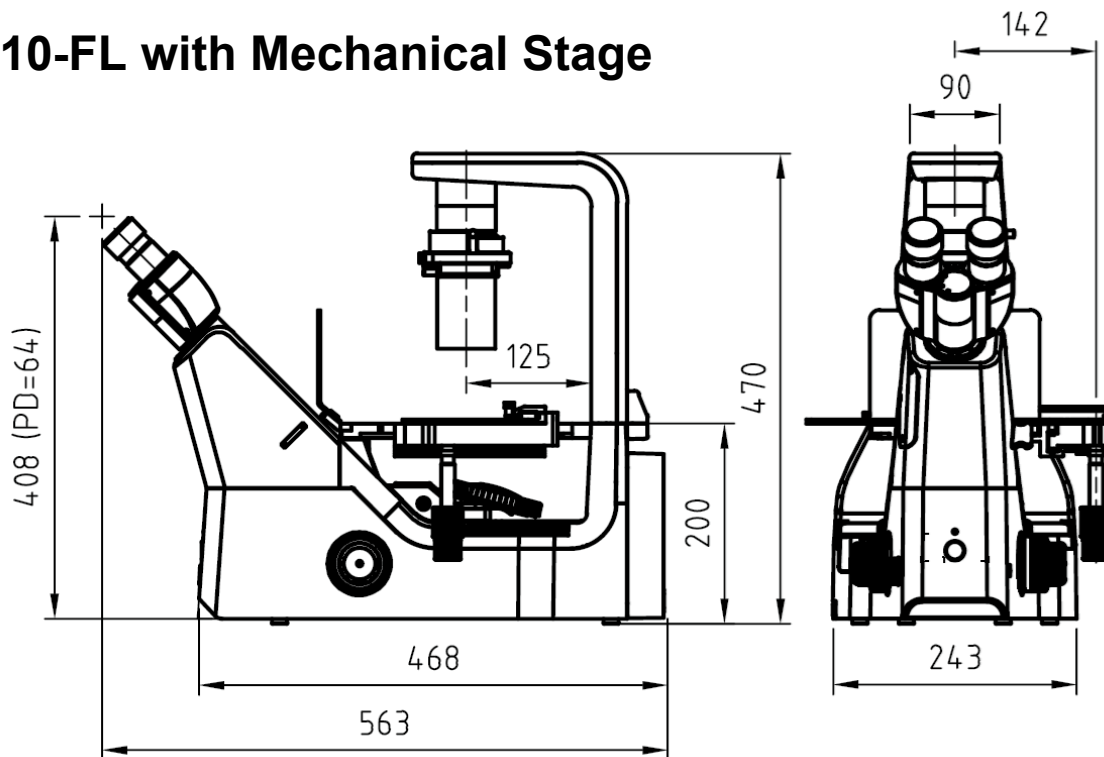

ASSEMBLY DIAGRAM

The diagram below shows how to assemble the various components. The numbers indicate the order of assembly. Use the hex wrenches that are supplied with your microscope when required. Be sure to keep these wrenches for changing out components or making adjustments.

When assembling the microscope, make sure that all parts are free of dust and dirt, and avoid scratching any parts or touching glass surfaces.

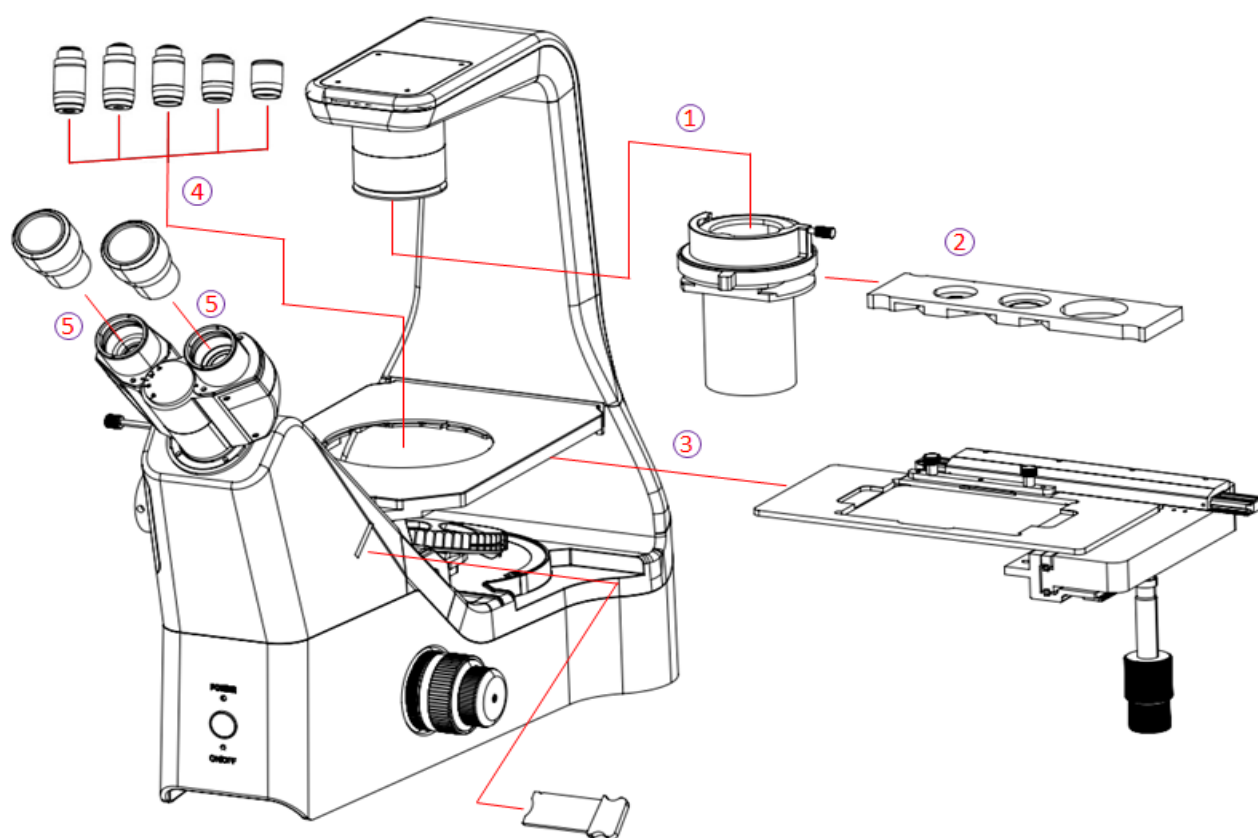

ASSEMBLY

Condenser

To install the condenser:

1. Unscrew the condenser set screw sufficiently to allow the condenser tube to slide over the dovetail groove of the condenser hanger.
2. Lightly press the condenser into position and tighten the set screw.

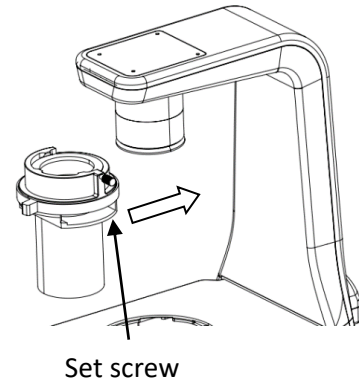

Phase Contrast Slider

To install the phase contrast slider:

1. With the printed notations on the slider facing up and readable from the front of the microscope, insert the phase contrast slider horizontally into the condenser slot. The orientation of the slider is correct if the edge of the slider facing the operator has adjusting screws visible.
2. Continue to insert the slider until an audible "click" indicates that one position of the 3-position phase contrast slider is aligned with the optical axis. Insert the slider further into the slot or backward to the desired slider position.

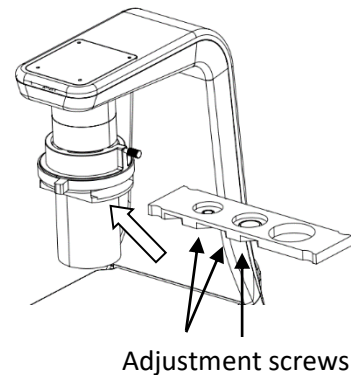

Mechanical Stage (optional)

To install the optional mechanical stage:

1. Install the mechanical according to path ① (as shown in the figure). First, align the edge **A** of the mechanical stage with the edge of the flat/plain stage surface. Align the mechanical stage with the plain stage until the two set screws in the bottom of the mechanical stage align with screw holes in the bottom of the plain stage. Tighten the two set screws.
2. Install the universal holder according to path ② (as shown in the figure). Start by placing the flat universal holder plate on the plain stage surface. Align the two screw holes on the universal holder plate with the set screws on the lateral movement ruler of the mechanical stage. Tighten the two set screws.

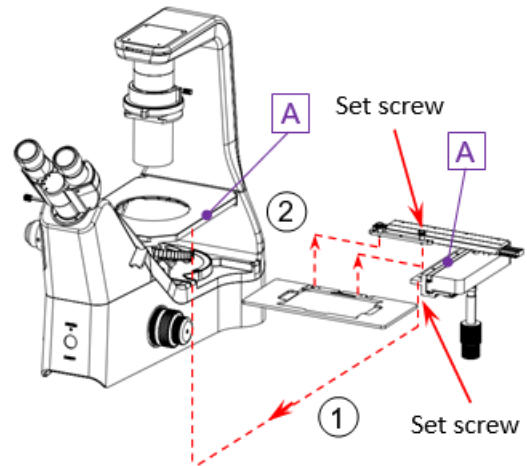

Objectives

To install the objectives:

1. Turn the coarse adjustment knob ① until the revolving nosepiece is at its lowest position.
2. Remove the nosepiece cap ② closest to you and thread the lowest magnification objective onto the nosepiece opening, then rotate the nosepiece clockwise and thread the other objectives from low to high magnification.

- NOTE:
- Always rotate the nosepiece by using the knurled nosepiece ring.
 - Keep the covers on any unused nosepiece openings to prevent dust and dirt from getting inside.

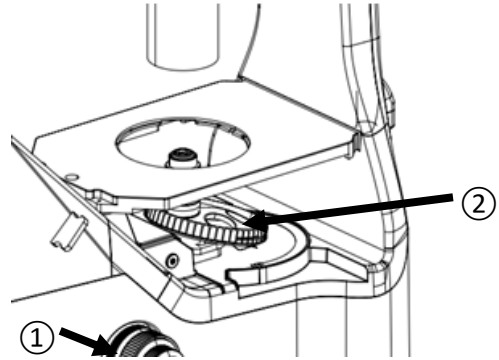

Stage Plate

Insert the clear glass stage plate ① into the opening on the stage. The clear glass allows you to view the objective in position.

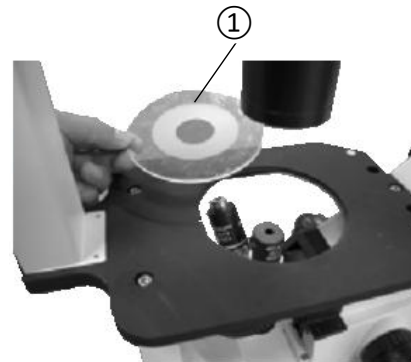

Eyepieces

Remove the eyetube plugs and fully insert the eyepieces ① into the eyepiece tubes ②.

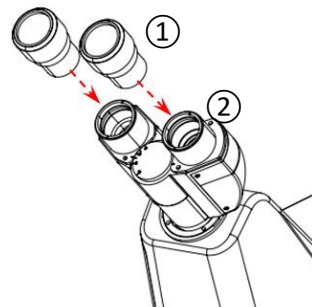

EXI-410 INVERTED MICROSCOPE SERIES

Camera (optional)

To install the optional camera:

1. Remove dust cover from 1X relay lens.
2. Thread the camera into the relay lens as shown.
NOTE: ● Always keep one hand on the camera to prevent it from falling.
3. Several camera relay lens magnifications are available depending on application and/or camera sensor size.
 - a. A 1X lens is standard and included with the microscope. This magnification is suitable for cameras with sensor diagonal sizes of 2/3" and larger.
 - b. A 0.7X lens (optional) will accommodate camera sensors of 1/2" to 2/3". Larger sensors may result in images with significant vignetting.
 - c. A 0.5X lens (optional) accommodates 1/2" camera sensors and smaller. Larger sensors may result in images with significant vignetting.

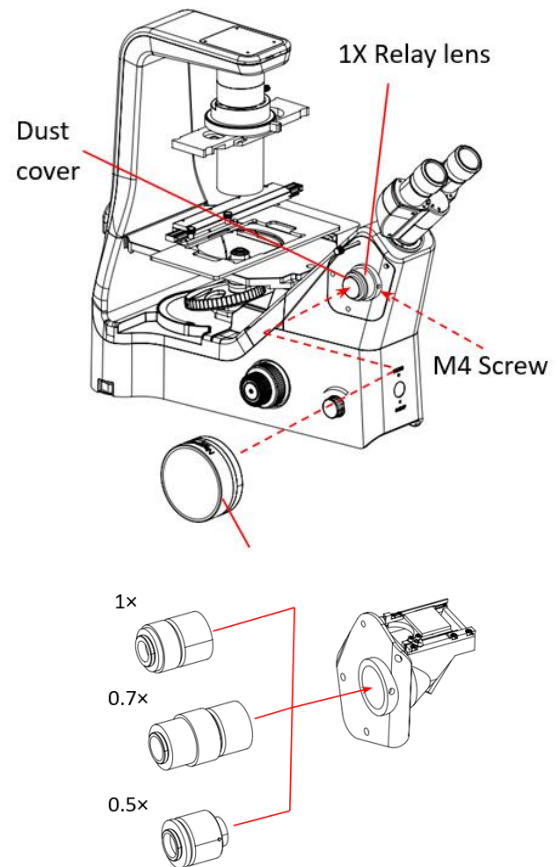

Monitor Mount (CAT# 410-MM) and HD Monitor Installation (optional)

1. Remove cover plate.
2. Install monitor mounting block using the longer screws provided with the mounting block.
3. Attach the monitor to the mounting block using the two (2) black 16mm screws and 2.5mm hex tool provided



Fluorescence Filter Cubes (EXI-410-FL models only)

TO PREVENT DAMAGE TO THE FILTER CUBES OR MICROSCOPE, THE FILTER CUBES MUST BE PLACED CORRECTLY.

PLEASE READ AND CAREFULLY FOLLOW THESE INSTRUCTIONS.

HANDLING THE FILTER CUBES

- Never touch any area of the filter cube other than the black casing.
- Be sure to carefully reinstall the turret cover to avoid breakage.
- Fluorescence filter sets must match the fluorescence LED excitation light source and the fluorescence probes used in the application. Please contact ACCU-SCOPE with any questions about compatibility.
- If replacing an existing filter cube, remove that filter cube first from the position into which the new filter cube will be placed **by grasping the cube on the sides with your thumb and forefinger and slide the cube out (you will feel it “unclick” – see page 17).**

Installing Fluorescence Filter Cubes

1. Remove the cover from the fluorescence turret access door on the left side of the microscope by pulling the cover handle.
2. Rotate the filter turret **by hand from the notches on the top of the turret** to a position that accepts a filter cube.

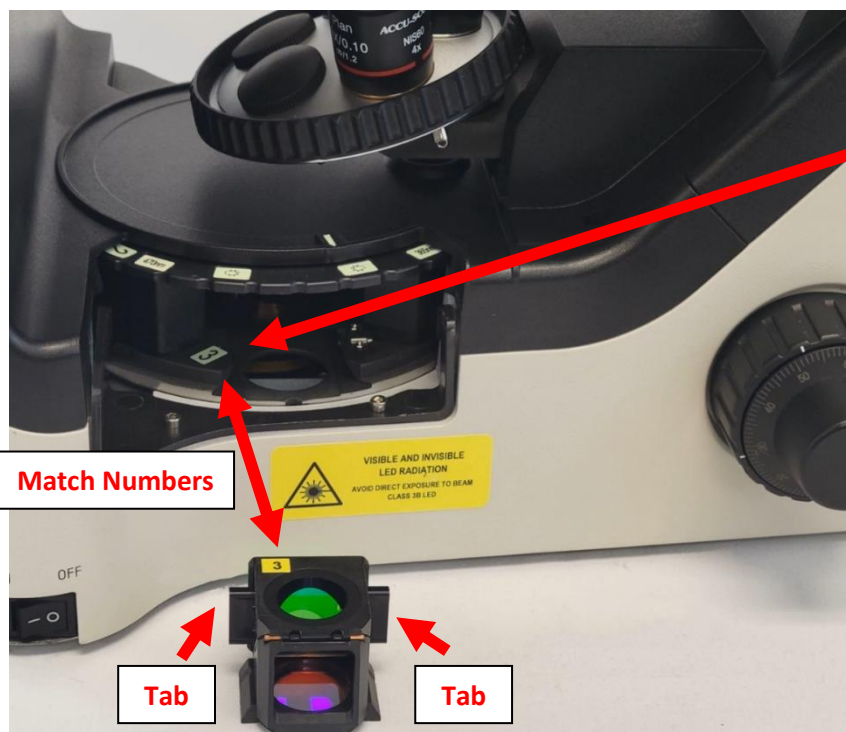
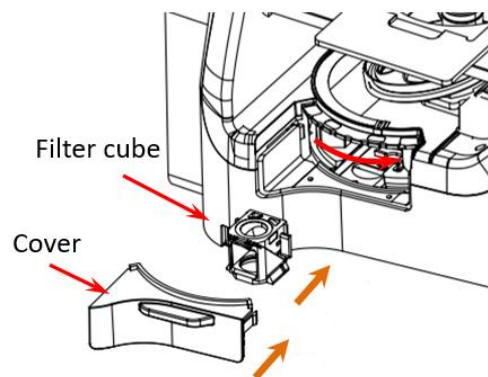

3. Cubes are **numbered** according to their position in the turret. **Match** the number on the cube to the position number on the turret.

The cubes should also be installed with the **TABS** on the cube inserted facing toward the back of the cube slot.

BEFORE INSTALLING THE CUBES SEE NEXT PAGE FOR PROPER ALIGNMENT

Installing Fluorescence Filter Cubes *(continued)*

NOTE: There is a **securing pin** on the right side of the inside of the turret for each filter position and **guide grooves** (see below, left).

Each filter cube has **notches** on the bottom left and right sides of the cube (see below, right). The filter cube will be installed properly when the **notch** on the bottom right side clicks into place on the **securing pin**.

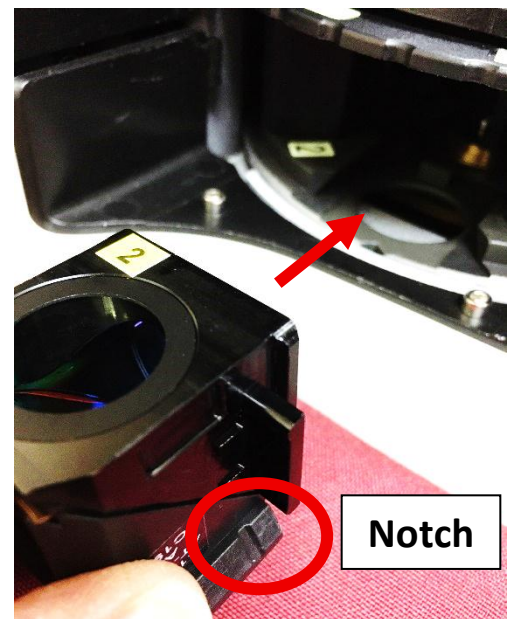
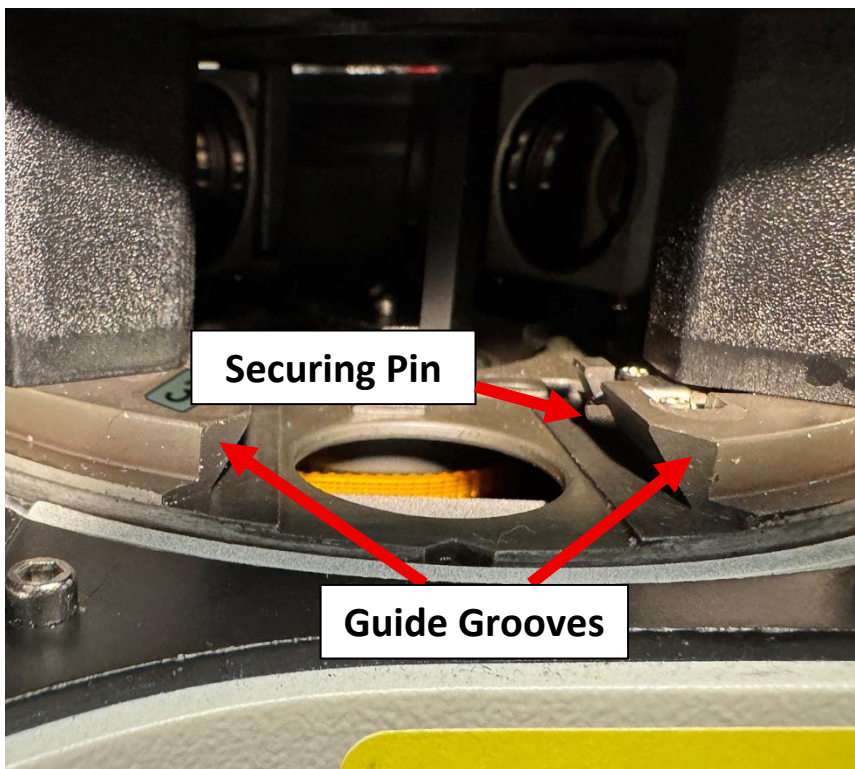

**BEFORE INSTALLING THE CUBES
SEE NEXT PAGE FOR
FINAL CUBE INSTALLATION**

Installing Fluorescence Filter Cubes *(continued)*



4. To install a filter cube, align the cube with the **TABS** facing toward the slot and slide the filter cube between the **GUIDE GROOVES** until the notch clicks into place on the **SECURING PIN**.

When the filter cube is inserted correctly, you will feel and/or hear a "click."

5. Above shows the filter cube is properly installed.
6. Replace the filter turret cover.

Power Cord

VOLTAGE CHECK

Confirm that the input voltage indicated on the rear label of the microscope corresponds to your line voltage. The use of a different input voltage than indicated will cause severe damage to your microscope.

Connecting the Power Cord

Make sure the On/Off Switch is "O" (the off position) before connecting the power cord.

Insert the power plug into the power outlet of the microscope; make sure the connection is snug.

Plug the power cord into a power supply receptacle.

NOTE: Always use the power cord that came with your microscope. If your power cord becomes damaged or lost, please call your authorized ACCU-SCOPE dealer for a replacement.

OPERATION

Powering On

Plug the 3-prong line cord into the microscope power outlet and then into a grounded 120V or 220V A.C. electrical outlet. Usage of a surge suppressor outlet is highly recommended. Turn the illuminator switch ① to “—”, then press the illumination selector ② to toggle the light to on (power indicator ③ will light). For longer lamp life, always turn the illuminator variable intensity knob ④ to the lowest illumination intensity setting possible before turning the power on or off.

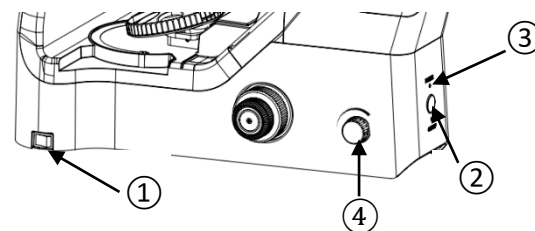

Adjusting the Illumination

The light level may need adjustment depending upon the specimen density and objective magnification. Adjust the light intensity for comfortable viewing by turning the light intensity control knob ④ clockwise (towards the operator) to increase brightness. Turn counterclockwise (away from the operator) to decrease brightness.

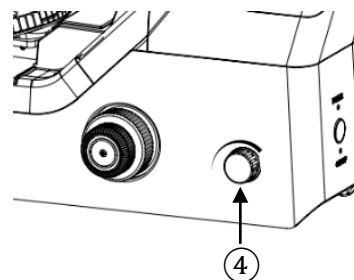

Adjusting Interpupillary Distance

To adjust the interpupillary distance, hold the left and right eyetubes while observing a specimen. Rotate the eyetubes around the central axis until the fields of view of both eyetubes coincide completely. A complete circle should be seen in the viewing field when viewing the specimen slide. An improper adjustment will cause operator fatigue and will disrupt the objective parfocality.

Where the “●” ① on the eyepiece tube lines up, that is the number for your interpupillary distance. The range is 54-75mm. Make note of your interpupillary number for future operation.



Operation (continued)

Adjusting the Focus

To ensure that you obtain sharp images with both eyes, (since eyes vary, especially for those wearing glasses) any eyesight variation can be corrected in the following manner. Set both diopter collars ② to "0". Using your left eye only and the 10X objective, focus your specimen by adjusting the coarse adjustment knob. When the image is in view, refine the image to its sharpest focus by turning the fine adjustment knob. Rotate the diopter collar to obtain the sharpest focus. To obtain the same sharp image using your right eye, do not touch the coarse or fine adjustments. Instead, rotate the right diopter collar until the sharpest image appears. Repeat several times to check.



IMPORTANT: do not counter rotate the focusing knobs as this will cause severe problems and damage to the focusing system.

Focusing on a Specimen

To adjust focus, rotate the focus knobs on the right or left sides of the microscope to move the objective up and down. Coarse focus ① and fine focus ② knobs are identified in the figure to the right.

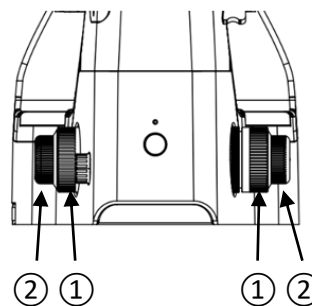

The figure to the right illustrates the relationship between the rotational direction of the focus knobs and the vertical motion of the objective.

Focus travel: The default focus travel from the surface of the plain stage is up 7mm and down 1.5mm. The limit can be increased up to 18.5mm by adjusting the limit screw.

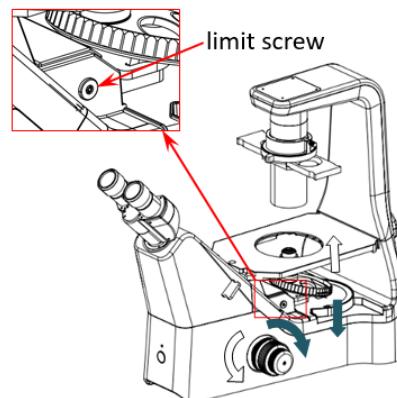

Operation (continued)

Adjusting the Focusing Tension

If the feel is very heavy when focusing with the focusing knobs ②③, or the specimen leaves the focus plane after focusing, or the stage lowers by itself, adjust the tension with the tension adjustment ring ①. The tension ring is the inner most ring with the focus knobs.

Turn the tension adjustment ring clockwise to loosen or counterclockwise to tighten according to user preference.

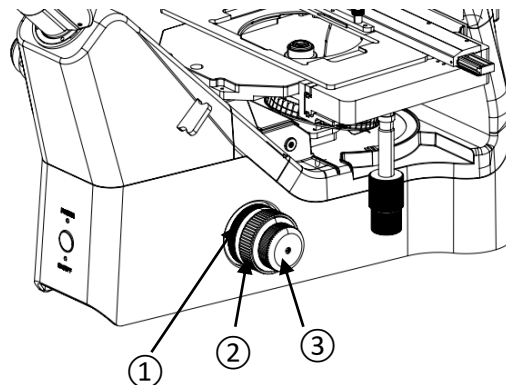

Using the Stage Plates (Optional)

NOTE: for optimal viewing, ensure the thickness of the container, dish or slide matches the thickness marked on each objective (0.17mm or 1.2mm). For modern objectives, coverglass is optimally 0.17mm thick (No. 1½), whereas most tissue culture vessels are 1-1.2mm thick. A mismatch between slide/vessel thickness and that for which the objective was designed will likely present an out-of-focus image.

With the mechanical stage ①, a user can use any of the optional stage plates for flasks, well plates, culture dishes or slides. The figure to the right illustrates the combination 60mm Petri dish/microscope slide holder ② mounted in the universal holder of the mechanical stage. The specimen holder can then be moved by turning the X③ and Y④ stage movement controls.

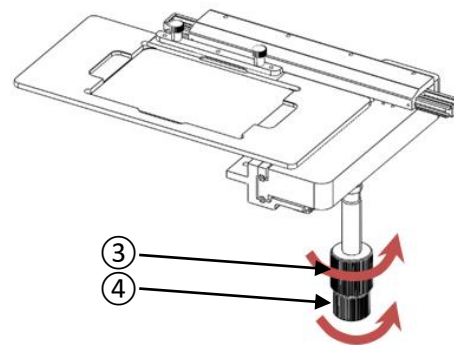
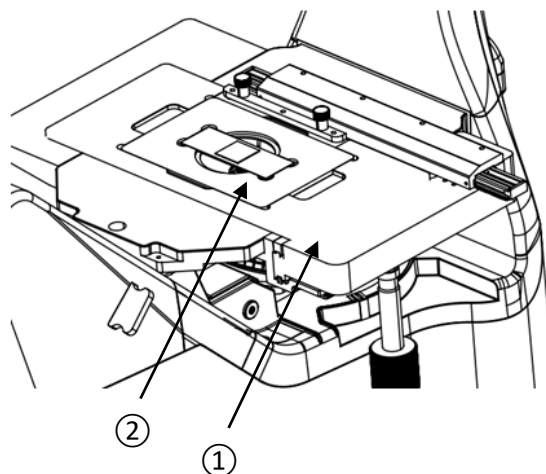

Operation (continued)

Selecting the Light Path

The EXI-410 is outfitted with a binocular viewing head with one camera port for digital imaging. You must select the appropriate light path for observing and imaging specimens.

When the light path selection slider ① is set to the “IN” position (pushed all the way in to the microscope), the light path sends 100% of the light to the binocular eyepieces.

When the light path selection slider is in the “OUT” position (pulled all the way to the left, away from the microscope), 20% of the light is sent to the binocular eyepieces and 80% of the light is directed to the camera port for observation and imaging with a digital camera.

For fluorescence units, the light path is configured for either 100% to the binocular viewing head (“IN” position), or 100% to the camera port (“OUT” position).

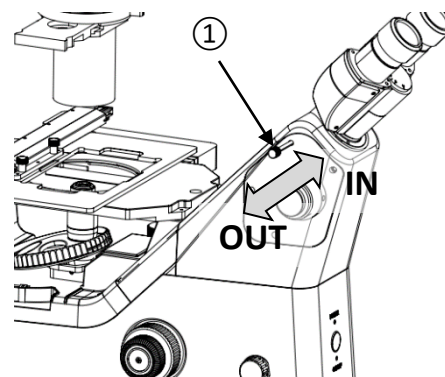

Using the Aperture Diaphragm

The iris diaphragm determines the numerical aperture (N.A.) of the illumination system in bright field observation. When the N.A. of the objective and the illumination system match, you obtain the optimal balance of image resolution and contrast, as well as an increased depth of focus.

To check the iris diaphragm: remove the eyepiece and insert the centering telescope (if you purchased one). When observing through the eyepiece, you will see the field of view as shown in the figure on the right. Adjust the iris diaphragm lever to the desired contrast.

When observing a dyed specimen, set the iris diaphragm ② to 70-80% of the N.A. of the objective ① in use. However, when observing a live culture specimen that is not dyed (has virtually no color), set the iris diaphragm to 75% of the **N.A. of the objective** in use.

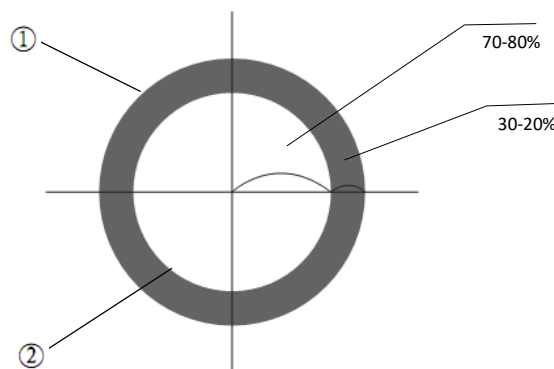
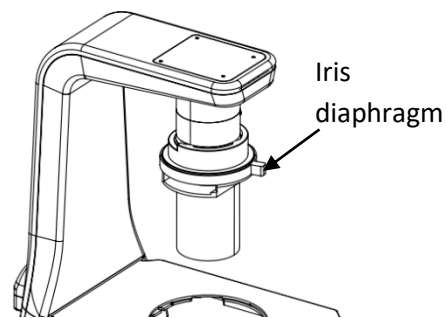

NOTE: An iris diaphragm that is closed too far will give optical artifacts in the image. An iris diaphragm that is too open may make the image appear too “washed out”.

Operation (continued)

Phase Contrast Observation

Depending on the configuration ordered, the EXI-410 can be used for phase contrast observation with LWD phase contrast objectives: 4x, 10x, 20x and 40x.

For phase contrast observation, replace the normal objectives with phase contrast objectives on the nosepiece – refer to page 8 for objective installation instructions. Brightfield observation can still be performed with phase contrast objectives, but phase contrast observation requires phase contrast objectives.

Phase Contrast Slider

The adjustable phase slider is pre-aligned at our facility, so further adjustment is not typically necessary. If the phase ring is not centered, you can adjust it by centering the bolt with the 2mm hex wrench provided with the microscope – see instructions below.

The EXI-410-PH includes a 3-position phase slider. Position 1 is for the 4x objective; Position 2 is for the 10x/20x/40x objectives. Position 3 is “open” for use with optional filters.

Match the 4x and 10x/20x/40x light annuli with phase contrast objectives of matching magnifications.

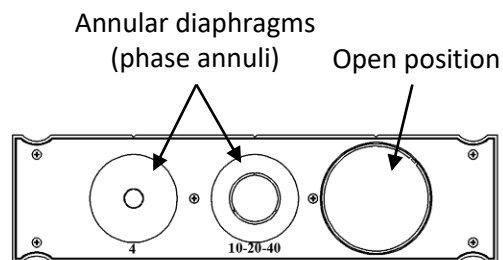

Installing the Phase Slider (Optional) (Refer to Page 14)

Centering the Light Annulus

The phase slider is pre-aligned at our facilities. If realignment is necessary, follow these steps:

1. Place a specimen on the stage and bring it into focus.
2. Replace the eyepiece in the eyepiece tube with the centering telescope (optional).
3. Make sure the magnification of the objective in the light path matches that of the light annulus on the phase slider.

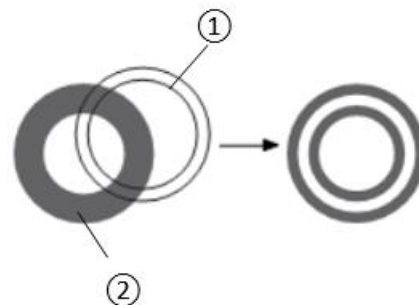

Operation (continued)

Centering the Light Annulus (Continued)

4. While observing through the centering telescope, adjust its focus on the phase annulus ② of the objective and corresponding light annulus ①. Refer to figure on previous page.
5. Insert the 2mm hex wrench into the two centering screw holes on the phase slider ③. Tighten and loosen the centering screws until the light annulus is superimposed on the phase annulus of the objective.
6. Repeat the steps above to adjust centering with other objectives and corresponding light annuli.

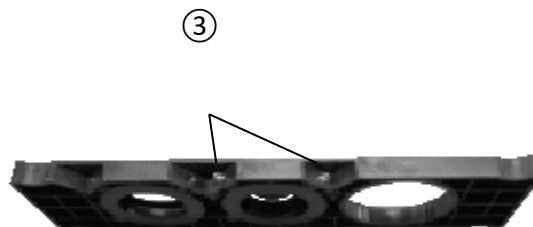

NOTES:

- Halo-like ghost images of the light annulus may sometimes appear. If this occurs, superimpose the brightest light annulus image over the phase annulus.
- When a thick specimen is moved or replaced, the light annulus and the phase annulus may deviate. This is usually due to the amount of media or certain wellplate inconsistencies. This can reduce image contrast. If this occurs, repeat steps 1-5 for readjustment.
- The centering procedure may have to be repeated in order to get the best possible contrast if a specimen slide or the bottom surface of a culture vessel is not flat. Center the light annulus using objectives in the order of lower to higher magnifications.

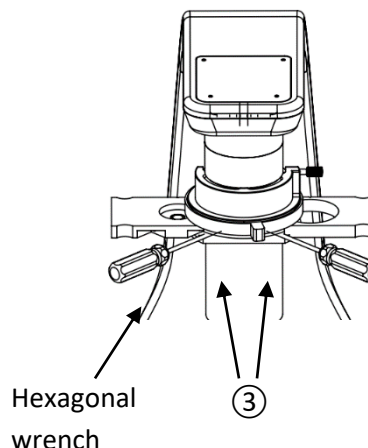

Emboss Contrast Observation

Emboss contrast microscopy requires a condenser-side emboss contrast slider and eyepiece-tube-side emboss contrast slider. These were shipped with the microscope and the installation and operation instructions are below.

Condenser-side Emboss Contrast Slider

The condenser-side emboss contrast slider is equipped with a sector diaphragm. Attaching a centering telescope to the eyepiece tube enables you to view a sector diaphragm image.

You can change the direction of image contrast by rotating the condenser-side emboss contrast slider adjuster to turn the sector diaphragm.

To use the condenser-side emboss contrast slider, first remove the phase contrast slider from the condenser. Then insert the condenser-side emboss contrast slider into the condenser slider slot ①.

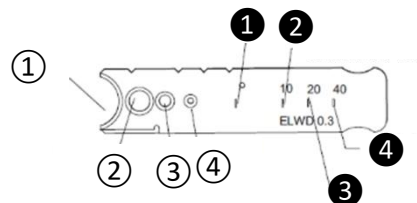
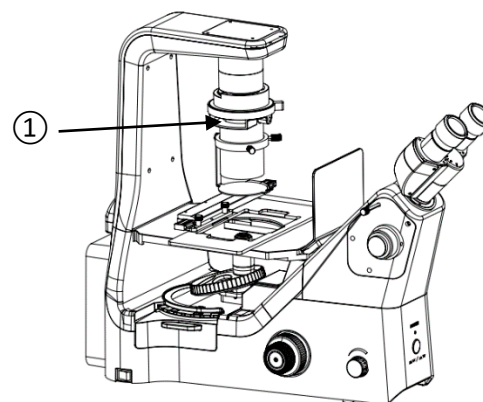
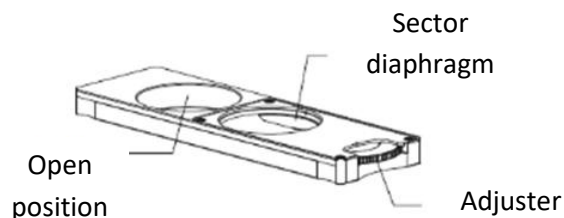

Eyepiece-side Emboss Contrast Slider

The eyepiece-tube-side emboss contrast slider has several position markings corresponding to the objective magnification, and several stop positions to ensure alignment of the apertures with the light path. For emboss contrast microscopy, insert the slider into the microscope until it reaches the position of the same number as the magnification of the objective. To switch back to bright-field microscopy, pull out the slider up to the hollow position. Slider position ① corresponds with aperture ①, ② with ②, and so forth.

For observation without emboss contrast, ensure the condenser-side emboss contrast slider is in the open position, and the eyepiece-side slider is in position ①.

Using a Microscopy Camera (Optional)

Installing Camera Couplers (Refer to Page 14)

Selecting the Light Path for Observation/Imaging with a Camera (Refer to Page 21)

Using Fluorescence (EXI-410-FL only)

If you purchased your EXI-410 with fluorescence, your complete fluorescence system is pre-installed, aligned and tested by our trained technicians to your specifications prior to shipment.

The complete fluorescence illumination light path includes:

- Integrated LED fluorescence illumination modules
- Dovetail filter slider
- 3 position fluorescence filter turret.

Each position of the filter turret features positive click stop ball-bearing positioning and printed markings above the knurled wheel identifying the turret position in the light path.

Refer to pages 8-10 for component diagrams of the EXI-410-FL.

The EXI-410-FL is not available with alternate light sources for fluorescence.

Various filter sets are also available for installation. Selection of filter sets depends upon the available LED fluorescence modules in your microscope. Contact your authorized ACCU-SCOPE dealer, or call us at 631-864-1000 for a list of available and recommended filter sets.

Operating Fluorescence (EXI-410-FL only)

Epi-fluorescence illumination

As right figure shown, press the illumination selector button to switch between epi-fluorescence illumination and transmitted illumination modes.

The intensity of the fluorescence LED illumination will increase when rotating direction of illumination intensity adjustment knob as in the figure on the right, the same as when using transmitted LED illumination.

NOTE: To minimize photobleaching of the specimen and avoid “autofluorescence” from the transmitted LED light module, ensure that the light shield is rotated into its down position (as shown in the figure to the right).

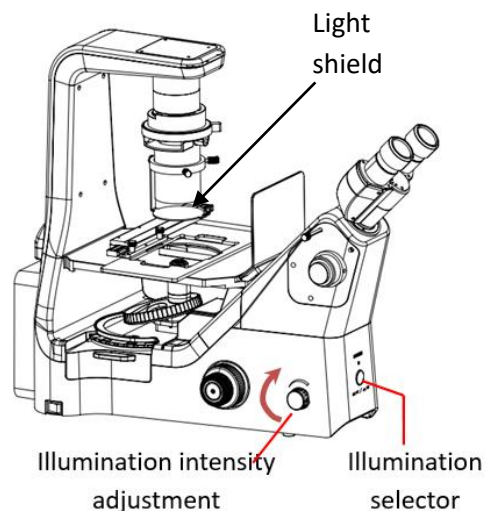

Using Fluorescence *(continued)*

Fluorescence Cube Turret

The fluorescence cube turret directs excitation illumination light from the fluorescence LED unit into the objective. The turret accepts up to three filter cubes.

Change the filter in the light path by rotating the filter cube turret. When the filter cube is switched, the fluorescence LED unit is also automatically switched.

Brightfield positions on the turret are indicated by a  symbol and alternate with the three fluorescence filter cube positions. Detents on the turret indicate when a filter cube or brightfield position is engaged. The position of the filter turret is visible on the edge of the turret wheel from both the left and right sides of the microscope. When switching the filter cube, check that the turret clicks at the desired filter cube or brightfield position.

NOTE: a UV light shield is included with the EXI-410-FL version to reduce extraneous light from the fluorescence sample.

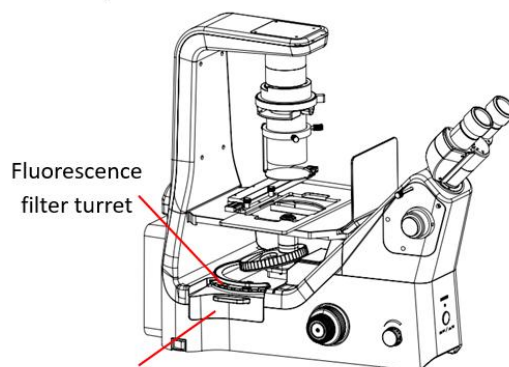

Fluorescence Filter Turret
Access Door

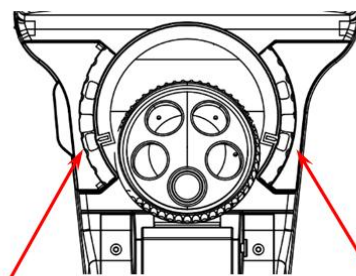

Filter cube position
indication

Filter cube position
indication

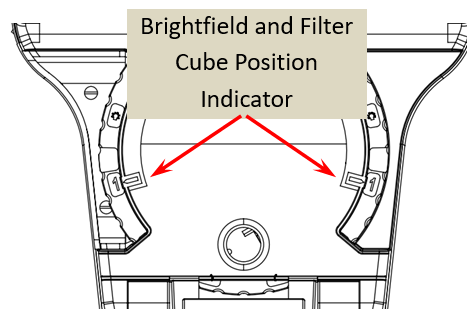

Brightfield and Filter
Cube Position
Indicator

TROUBLESHOOTING

Under certain conditions, performance of this unit may be adversely affected by factors other than defects. If a problem occurs, please review the following list and take remedial action as needed. If you cannot solve the problem after checking the entire list, please contact your local dealer for assistance.

OPTICAL

PROBLEM	CAUSE	SOLUTION
The illumination is on, but the field of view is dark.	The LED bulb is burnt out.	Replace it with a new one.
	The brightness is set too low.	Set it to the appropriate position.
	Too many filters are stacked.	Reduce them to the minimum required number.
The edge of the field of view is obscured or not evenly illuminated.	The nosepiece is not in the located position.	Turn the nosepiece into the position where you can hear it engaged.
	The color filter is not inserted fully.	Push it in all the way.
	The phase contrast slider is not located in the proper position.	Move the slider until it clicks into place.
Dirt or dust is visible in the field of view. – or – The image has glare.	Dirt/dust on the specimen.	Clean or replace the specimen.
	Dirt/dust on the eyepiece.	Clean the eyepieces.
	The iris diaphragm is closed too much.	Open the iris diaphragm more.
	The objective is not correctly engaged in the light path.	Turn the nosepiece into the engaged position.
Visibility is poor ● Image is not sharp ● Contrast is poor ● Details are indistinct	The aperture diaphragm is opened or stopped down too far in brightfield observation.	Adjust the aperture diaphragm properly.
	The lens (condenser, objective, ocular, or culture dish) become dirty.	Clean it thoroughly.
	In phase contrast observation, the bottom thickness of the culture dish is more than 1.2mm.	Use a culture dish whose bottom thickness is less than 1.2mm, or use a long working distance objective.
	Using a brightfield objective.	Change to a phase contrast objective.
	The light annulus of the condenser does not match the phase annulus of the objective.	Adjust the light annulus so that it matches the phase annulus of the objectives
	The light annulus and the phase annulus are not centered.	Adjust the centering screws to center it.

TROUBLESHOOTING *(continued)*

OPTICAL

<p>Visibility is poor <i>(continued)</i></p>	<p>The objective used is not compatible with phase contrast observation.</p> <p>When looking at the edge of the culture dish, the phase contrast ring and the light ring are deviated from each other.</p>	<p>Please use a compatible objective.</p> <p>Move the culture dish until you obtain the phase contrast effect. You may also remove the phase contrast slider, and set the field diaphragm lever to “”</p>
<p>Phase contrast effect cannot be obtained.</p>	<p>The objective is not in the center of the light path.</p> <p>The specimen is not correctly mounted on the stage.</p> <p>The optical performance of the culture vessel bottom plate is poor (profile irregularity, etc.).</p>	<p>Confirm that the nosepiece is in the “clicked” position.</p> <p>Place the specimen on the stage correctly.</p> <p>Use a vessel with a good profile irregularity characteristic.</p>

MECHANICAL PART

PROBLEM	CAUSE	SOLUTION
<p>The coarse adjustment knob is too difficult to rotate.</p>	<p>The tension adjustment ring is tightened too much.</p>	<p>Loosen it appropriately.</p>
<p>The image goes out of focus during observation.</p>	<p>The tension adjustment collar is too loose.</p>	<p>Tighten it appropriately.</p>

ELECTRICAL SYSTEM

PROBLEM	CAUSE	SOLUTION
<p>The lamp doesn't light</p>	<p>No power to the lamp</p>	<p>Check the power cord is connected correctly</p> <p>NOTE: Lamp Replacement The LED illuminator will provide approximately 20,000 hours of illumination under normal use. If you should need to replace the LED bulb, please contact an authorized ACCU-SCOPE service center or call ACCU-SCOPE at 1-888-289-2228 for an authorized service center near you.</p>
<p>The light intensity is not bright enough</p>	<p>Not using a designated lamp. The brightness adjustment knob is not adjusted properly.</p>	<p>Use n designated lamp. Adjust the brightness adjustment knob in a correct way.</p>

MISCELLANEOUS

<p>The field of view of one eye does not match that of the other</p>	<p>The interpupillary distance is not correct. The diopter is not right. Your view is not accustomed to the microscope observation and widefield eyepieces.</p>	<p>Adjust the interpupillary distance. Adjust the diopter. Upon looking into eyepieces, try looking at the overall field before concentrating on the specimen range. You may also find it helpful to look up and into distance for a moment before looking into the microscope again.</p>
<p>The indoor window or the fluorescence lamp is imaged.</p>	<p>The stray light enters through the eyepieces and is reflected to the camera.</p>	<p>Cap/cover both the eyepieces before imaging.</p>

MAINTENANCE

Please remember to **never** leave the microscope with any of the objectives or eyepieces removed and always protect the microscope with the dust cover when not in use.

SERVICE

ACCU-SCOPE® microscopes are precision instruments which require periodic servicing to keep them performing properly and to compensate for normal wear. A regular schedule of preventative maintenance by qualified personnel is highly recommended. Your authorized ACCU-SCOPE® distributor can arrange for this service. Should unexpected problems be experienced with your instrument, proceed as follows:

1. Contact the ACCU-SCOPE® distributor from whom you purchased the microscope. Some problems can be resolved simply over the telephone.
2. If it is determined that the microscope should be returned to your ACCU-SCOPE® distributor or to ACCU-SCOPE® for warranty repair, pack the instrument in its original Styrofoam shipping carton. If you no longer have this carton, pack the microscope in a crush-resistant carton with a minimum of three inches of a shock absorbing material surrounding it to prevent in-transit damage. The microscope should be wrapped in a plastic bag to prevent Styrofoam dust from damaging the microscope. Always ship the microscope in an upright position; **NEVER SHIP A MICROSCOPE ON ITS SIDE**. The microscope or component should be shipped prepaid and insured.

LIMITED MICROSCOPE WARRANTY

This microscope and its electronic components are warranted to be free from defects in material and workmanship for a period of five years from the date of invoice to the original (end user) purchaser. LED lamps are warranted for a period of one year from the date of original invoice to the original (end user) purchaser. The mercury power supply is warranted for a period of one year from the date of invoice to the original (end user) purchaser. This warranty does not cover damage caused in-transit, misuse, neglect, abuse or damage resulting from improper servicing or modification by other than ACCU-SCOPE approved service personnel. This warranty does not cover any routine maintenance work or any other work, which is reasonably expected to be performed by the purchaser. Normal wear is excluded from this warranty. No responsibility is assumed for unsatisfactory operating performance due to environmental conditions such as humidity, dust, corrosive chemicals, deposition of oil or other foreign matter, spillage or other conditions beyond the control of ACCU-SCOPE INC. This warranty expressly excludes any liability by ACCU-SCOPE INC. for consequential loss or damage on any grounds, such as (but not limited to) the non-availability to the End User of the product(s) under warranty or the need to repair work processes. Should any defect in material, workmanship or electronic component occur under this warranty contact your ACCU-SCOPE distributor or ACCU-SCOPE at (631) 864-1000. This warranty is limited to the continental United States of America. All items returned for warranty repair must be sent freight prepaid and insured to ACCU-SCOPE INC., 73 Mall Drive, Commack, NY 11725 – USA. All warranty repairs will be returned freight prepaid to any destination within the continental United States of America, for all foreign warranty repairs return freight charges are the responsibility of the individual/company who returned the merchandise for repair.

ACCU-SCOPE is a registered trademark of ACCU-SCOPE INC., Commack, NY 11725

v102225